

OWNER'S MANUAL

Assembly & Operating Instructions

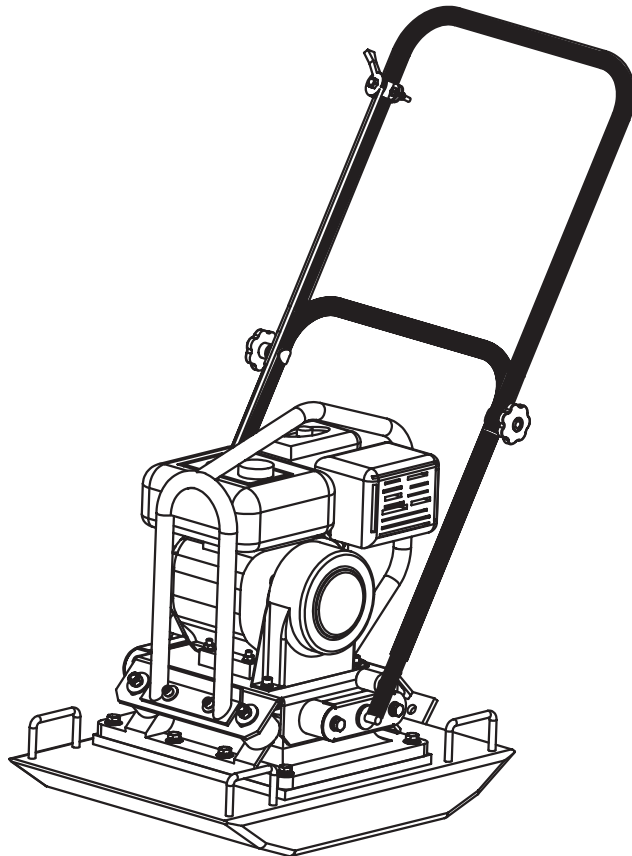

FORWARD PLATE COMPACTOR

COM20F.V24



Thank you for choosing our Equipment. It was carefully engineered to provide excellent performance when properly operated and maintained.

Please read this entire manual before operating the Equipment. It instructs you on how to set up, operate, and maintain your Equipment safely and easily. Ensure that you and any other persons operating the Equipment carefully follow the recommended safety practices at all times, as failure to do so could result in personal injury or property damage.

All information in this manual is relevant to the most recent product information available at the time of printing. Review this manual frequently to familiarize yourself with the machine, its features, and operation. Please note that this Owner's Manual may cover a range of product specifications for various models. Characteristics and features discussed and/or illustrated in this manual may not be applicable to all models. We reserve the right to change product specifications, designs, and equipment without notice and without incurring obligation.

All the power testing information used to establish the power rating of the engine equipped on this Equipment can be found in the engine manufacturer's manual or website. If you encounter any problems or have questions about the machine, please contact our Customer Support Department.

Throughout this manual, all references to the right and left side of the Equipment are observed from the operating position. The engine manufacturer is responsible for all engine-related issues concerning performance, power-rating, specifications, warranty, and service. Refer to the engine manufacturer's Owner's Manual, packed separately with your Equipment, for more information.

Customer Support

Before initiating a product return, kindly reach out to our dedicated Customer Support Department at Bigger Boyz Toyz. We are here to assist you.

Phone: 02 4257 4787

Email: bbt@bbta.com.au

Warehouse: Unit 2/3 Delta Place, Albion Park Rail NSW 2527

If you have difficulty assembling the product or have any questions about the controls, operations, or maintenance of the equipment, please don't hesitate to get in touch with our Customer Support Department.

CONTENTS

| | |
|-----------------------------------------------------------|-----------|
| SAFETY & ALERT SYMBOLS | 4 |
| FOR YOUR SAFETY AND THE SAFETY OF <u>OTHERS!</u> | 4 |
| ADDITIONAL INFORMATION AND POTENTIAL CHANGES | 4 |
| HAZARDS SYMBOLS | 5 |
| GENERAL SAFETY | 6 |
| TRANSPORTING | 7 |
| MAINTENANCE..... | 7 |
| EMERGENCIES..... | 7 |
| ADDITIONAL HAZARD | 7 |
| GENERAL INFORMATION | 8 |
| APPLICATIONS | 8 |
| CONSTRUCTION | 8 |
| CONTROLS | 8 |
| OPERATION | 9 |
| GENERAL OPERATION..... | 9 |
| PRIOR TO OPERATION | 9 |
| STARTING | 11 |
| OPERATION | 12 |
| TRANSPORTATION..... | 12 |
| SHUTDOWN..... | 13 |
| SERVICE&STORAGE | 14 |
| MAINTENANCE | 15 |
| SERVICE | 15 |
| TROUBLESHOOTING | 16 |
| REPLACEMENT PARTS LIST | 17 |
| MAJOR COMPONENTS | 18 |
| VIBRATOR ASSY | 20 |

SAFETY & ALERT SYMBOLS

FOR YOUR SAFETY AND THE SAFETY OF OTHERS!



Safety precautions should be followed all the time when operating this equipment. Failure to read and understand the Safety Messages and Operating Instructions could result in injury to yourself and others



This Operating Instructions has been developed to provide complete instructions for the safe and efficient operation of this equipment. Refer to the engine manufactures instructions for data relative to its safe operation.



WARNING: Read and thoroughly understand all instructions in this equipment and on the safety decals before assembling or operating this equipment. Failure to do so may cause serious injury or death. Do not allow anyone to operate this equipment who has not read this manual. As with all power equipment, this equipment can be dangerous if assembled or used improperly. Do not operate this equipment if you have any questions concerning its safe operation. Contact our Customer Support Department for assistance in addressing any queries or concerns.

This SAFETY ALERT SYMBOL identifies important safety messages in this manual. Failure to follow this important safety information may result in serious injury or death.



DANGER indicates a hazardous situation which, if not avoided, will result in serious injury or death.



WARNING indicates a hazardous situation which, if not avoided, could result in serious injury or death.



CAUTION indicates a hazardous situation which, if not avoided, could result in minor or moderate injury.

ADDITIONAL INFORMATION AND POTENTIAL CHANGES

We reserve the right to discontinue, change, and improve our products at any time without notice or obligation to the purchaser. The descriptions and sections contained in this manual were in effect at the time of printing. Equipment described within this manual may be optional. Some illustrations may not be applicable to your machine.















Your Responsibility—Restrict the use of this power machine to persons who have read, understood, and will follow the warnings and instructions in this manual and on the machine

SAVE THESE INSTRUCTIONS!

HAZARDS SYMBOLS

Potential hazards associated with the operation of this equipment will be referenced with Hazard Symbols which appear throughout this manual.

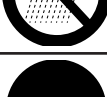
| | |
|-------------------------------------------------------------------------------------|-----------------------------------------------------------------------------------------------------------------------------------------------------------------------------------------------------------------------------------------------------------------------------------------------|
|  | READ THE OWNER'S MANUAL(S) : Read, understand and follow all instructions in the manual(s) before attempting to assemble and operate. |
|  | FACE PROTECTION : Always wear safety goggles or safety glasses with side shields or a face shield when operating this product as well as ear protection. |
|  | WEAR GLOVES : Always wear non-slip, heavy-duty protective gloves when operating this product. |
|  | WEAR SAFETY FOOTWEAR : Always wear non-slip steel-toed safety footwear when operating this product. |
|  | BEWARE OF ROTATING BLADES : This equipment has a rotating cutting blade capable of amputating hands and feet and throwing objects. Keep hands and feet out of openings while machine is running. Failure to observe these safety instructions could result in serious injury or death. |
|  | BEWARE OF FLYING OBJECTS : Beware of thrown objects, which can ricochet causing serious injury to the eyes. Always wear eye & ear protection when operating. |
|  | Never wear loose clothes or long jewellery and keep your long hair secured when operating machine. Never operate this machine in bare feet or sandals. Never use machine on a slope or hard smooth floor. |
|  | CARBON MONOXIDE AND GAS : Exhaust contains poisonous carbon monoxide, a colourless and odourless gas. Breathing exhaust fumes can cause loss of consciousness and may lead to death. |
|  | RESPIRATORY HAZARDS : ALWAYS wear approved respiratory protection when required. |
|  | PETROL OIL : Petrol is extremely flammable and the vapours are explosive. Serious personal injury can occur when petrol is spilled on you or your clothing, which can ignite. In the event of a petrol spill, wash your skin and change clothes immediately. |
|  | BURN HAZARDS : Engine components can produce intense heat. To avoid burns, DO NOT touch these areas while the engine is running or right after operations. Never operate the engine with removed heat shields or guards. |
|  | DO NOT use in the rain. |
|  | ACCIDENTAL STARTING HAZARDS : Always place the ON/OFF switch in the OFF position when the equipment is not in use. |

GENERAL SAFETY

- » DO NOT operate or service this equipment before reading this entire manual.
- » This equipment should not be operated by persons under 18 years of age.
- » NEVER operate this equipment without proper protective clothing, shatterproof glasses, steel-toed boots, and other protective devices required for the job.
- » NEVER operate this equipment when not feeling well due to fatigue, illness, or taking medicine.
- » NEVER operate this equipment under the influence of drugs or alcohol.
- » ALWAYS wear proper respiratory (mask), hearing, and eye protection equipment when operating this equipment.
- » Whenever necessary, replace the nameplate, operation, and safety decals when they become difficult to read.
- » The manufacturer does not assume responsibility for any accidents due to equipment modifications.
- » NEVER use accessories or attachments that are not recommended for this equipment. Damage to the equipment and/or injury to the user may result.
- » NEVER touch the hot exhaust manifold, muffler, or cylinder. Allow these parts to cool before servicing the engine or this equipment.
- » High Temperatures – Allow the engine to cool before adding fuel or performing service and maintenance functions. Contact with hot components can cause serious burns.
- » The engine section of this equipment requires an adequate free flow of cooling air. NEVER operate this equipment in any enclosed or narrow area where the free flow of air is restricted; it will cause serious damage to the equipment or engine and may cause injury to people.
- » ALWAYS refuel in a well-ventilated area, away from sparks and open flames.
- » ALWAYS use extreme caution when working with flammable liquids. When refuelling, stop the engine and allow it to cool.
- » NEVER operate this equipment in an explosive atmosphere or near combustible materials. An explosion or fire could result, causing severe bodily harm or even death.
- » DO NOT smoke around or near the machine. Fire or explosion could result from fuel vapours, or if fuel is spilled on a hot engine.
- » Topping-off to the filter port is dangerous, as it tends to spill fuel.
- » Stop the engine when leaving the equipment unattended.
- » Maintain this equipment in a safe operating condition at all times.
- » ALWAYS stop the engine before servicing, adding fuel and oil.
- » NEVER run the engine without an air filter. Severe engine damage may occur.
- » ALWAYS service the air cleaner frequently to prevent carburetor malfunctions.
- » ALWAYS check the equipment for loosened threads or bolts before starting.
- » ALWAYS ensure the operator is familiar with proper safety precautions and operational techniques before using the equipment.
- » ALWAYS store equipment properly when it is not being used. Equipment should be stored in a clean, dry location out of the reach of children.
- » DO NOT operate this equipment unless all guards and safety devices are attached and in place.
- » CAUTION must be exercised while servicing this equipment.
- » Keep all inexperienced and unauthorized people away from the equipment at all times.
- » Unauthorized equipment modifications will

void all warranties.

- » NEVER pour or spray water over the engine.
- » Test the engine ON/OFF switch before operating. The purpose of this switch is to shut down the engine of the equipment.
- » Refer to the Engine User's Manual for engine technical questions or information recommended for the equipment.

TRANSPORTING

- » ALWAYS shut down the engine before transporting.
- » Tighten the fuel tank cap securely and close the fuel cock to prevent fuel from spilling.
- » Drain fuel when transporting the equipment over long distances or bad roads.
- » When placing the equipment inside a truck bed for transport, always tie down the equipment.

MAINTENANCE

- » NEVER lubricate components or attempt service on a running equipment.
- » ALWAYS allow the equipment a proper amount of time to cool before servicing.
- » Keep the equipment in proper running condition.
- » Fix damage to the equipment immediately and always replace broken parts.
- » Dispose of hazardous waste properly. Examples of potentially hazardous waste are used motor oil, fuel, and fuel filters.
- » DO NOT use wooden or plastic containers to dispose of hazardous waste.

EMERGENCIES

- » ALWAYS know the location of the nearest fire extinguisher and first aid kit.
- » In emergencies, always know the location of the nearest phone or keep a phone on the job site. Also, know the phone numbers of the nearest ambulance, doctor, and

fire department. This information will be invaluable in the case of an emergency.

ADDITIONAL HAZARD

- » Ensure the area to be compacted is free of "live" electrical cables, gas, water, or communication services that could be damaged by vibration.
- » Exercise caution when operating the unit, as exposure to vibration or repetitive actions may be harmful to hands and arms.
- » Never stand on the unit while it is in operation.
- » Do not exceed the governed no-load motor speed of 3,500 r/min, as any increase may result in personal injury and machine damage.
- » Noise Hazards: Excessive noise can lead to temporary or permanent hearing loss.
- » Wear an approved hearing protection device to limit noise exposure, as required by Occupational Health and Safety regulations.
- » Additional Hazards: Slip/Trip/Fall is a significant cause of serious injury or death. Beware of uneven or slippery work surfaces.

GENERAL INFORMATION

APPLICATIONS

The plate compactor is a machine designed to compact the ground, aiming to achieve a smooth surface by transmitting vibrations through a vibrating plate. This power is generated from a single motor housed in the vibrator case. The machine is well-suited for tasks such as leveling soil, beaching, and finishing asphalt paving. Its applications include:

- » Trench compaction
- » Earthworks
- » Road maintenance
- » Landscaping
- » Brick paving
- » Driveway toppings

CAUTION

Improper Use and Misapplication:

This machine may face challenges when operated on soil with high water content, particularly clay soil, making it unsuitable for such conditions. Additionally, it may struggle to level ground containing large stones due to its limited compacting force. The plate compactor is primarily designed for surface smoothing and may not be effective for tasks requiring substantial compaction.

For projects involving deep ground compaction into lower layers, it is advisable to use specialized equipment such as a Tamping Rammer, Vibrato Compactor, or Vibration Roller, as they offer more efficient compacting force. Please reserve the use of this compactor for tasks specifically related to surface smoothing on soil, sediment, sand, beaching, and asphalt. It is not recommended for applications beyond these specifications.

CONSTRUCTION

The upper section comprises the Power Source, Handle, Belt Cover, and Guard Hook, all firmly attached to the Engine base. The Engine base is secured onto the Vibrating Plate using Shock Absorbing Rubber. The lower part consists of the Vibrating Plate and the Vibrator unit housing an Eccentric rotary shaft. Power transmission occurs from the centrifugal clutch on the engine output shaft to the eccentric rotary shaft via a V-belt.

Power Transfer: An air-cooled single-cylinder engine serves as the power source, with a Centrifugal Clutch fixed on the engine output shaft. Options include mounting a Petrol Engine (2-cycle, 4-cycle) or a Diesel Engine. The Centrifugal Clutch engages when the engine runs, reducing the engine speed to a suitable level for compaction. The engine's rotation is then transmitted from the V-pulley integrated with the Clutch drum to the Vibrator pulley through a V-belt. The Vibrator Pulley rotates the Eccentric rotor shaft within the Vibrator case. The resulting vibration generated by the eccentric rotor is transmitted to the ground, allowing for compaction with the weight of the machine.

CONTROLS

Motor: The motor is regulated using an ON/OFF switch or push button situated beneath the fuel tank. Remote speed control of the motor is facilitated by a throttle lever mounted on the machine handle. Honda and Kama motors come equipped with an oil alert device, designed to halt the motor or prevent starting if the crankcase oil level drops below a safe threshold.

Drive Belt: The tension of the drive belt is customizable. To adjust, loosen the four nuts on the bolts securing the motor to the base plate. Adjust the set screws, which bear against the motor crankcase, until the desired belt tension is achieved. Ensure that after adjustment, the four nuts and the lock nuts on the set screws are securely tightened.

OPERATION

GENERAL OPERATION

The machine is most effective for compacting bituminous and granular materials such as granular soils, gravels, sands, or mixtures of both. Cohesive soils like silt and clay are better compacted using the impact force generated by a vibrating rammer.

Ideally, the site should be graded and leveled before starting the compaction process.

Correct soil moisture content is crucial for proper compaction. Water serves as a lubricant to facilitate the sliding of soil particles together. Insufficient moisture results in inadequate compaction, while excessive moisture creates water-filled voids that weaken the soil's load-bearing capacity.

Use unleaded grade petrol and ensure that the fuel is free from contamination.

The vibratory motion provides a self-propelling action. Position the handle at the opposite end of the machine from the vibrator.

Start the motor using the recoil starter. If the motor has an on/off switch, turn it to ON before starting.

For detailed information on starting and correct operating procedures of the motor, refer to the motor operation manual supplied with the unit.

Increase the motor speed to the maximum setting using the hand throttle lever before beginning compaction.

Control the machine by grasping the handle with both hands and applying restraint to manage forward motion. If there are issues with forward or backward motion, adjust the red handle or nuts (items 21, 22 in the components list). Steer the machine by moving the handle sideways to the right or left.

Always maintain good footing to avoid slipping and losing control when starting or operating the machine.

PRIOR TO OPERATION

Ensure thorough removal of dirt, nuts, etc., from the unit before operation. Pay special attention to cleaning the button face of the vibrating plate and the areas near the cooling air inlet of the engine, carburetor, and air cleaner.

Inspect all bolts and screws for tightness, ensuring they are securely tightened. Loose bolts and screws may lead to unit damage.

Check the V-belt for tightness. The normal slack should be approximately 10-15 mm (1/2") when the belts are forcibly depressed in the middle position between the two sheaves. Excess belt play could result in a decrease in impact force or erratic vibration, potentially causing damage to the machine.

Verify the engine oil level, and if low, refill it using the recommended motor oil suggested in the provided table (Fig-1).

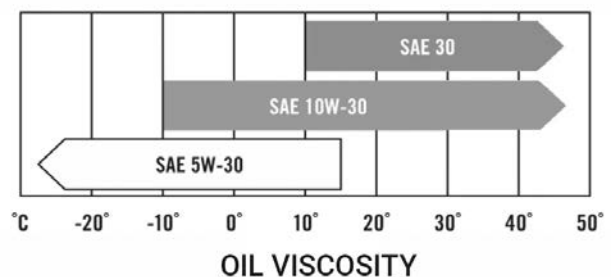
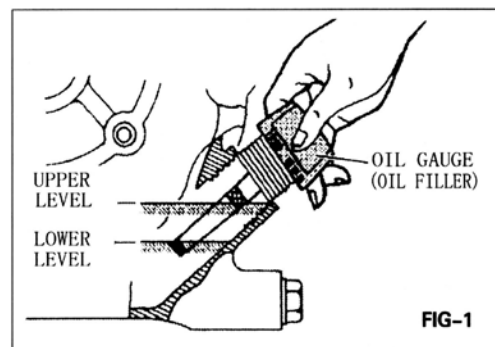

Remove the oil plug in the vibrator assembly and check the oil level. Ensure the compactor is level during inspection. The oil level should reach up to the oil plug. Replace the oil every month or after every 200 hours of operation.

NOTE: Use motor oil with SAE specification. During oil changes, drain the old oil by tilting the unit. It is recommended to perform this task when the oil is hot, as it facilitates easy drainage.

Use a regular-grade petrol for the engine. When refilling the fuel tank, ensure the use of a fuel filter.

CAUTION

- » Exercise caution regarding the operating place and ventilation. Avoid operating the machine in enclosed spaces like closed rooms or tunnels, as the exhaust contains the deadly poisonous gas carbon monoxide. If unavoidable, operate in such places; ensure proper ventilation by discharging the exhaust outside through suitable means.
- » Exercise caution around hot components. Mufflers and other hot parts can be dangerous; refrain from touching them with unprotected hands.
- » When transporting, secure the fuel tank cap tightly, and turn the fuel valve OFF at the source. Drain gasoline from the fuel tank before transporting over long distances or on rough roads.
- » Always stop the engine before replenishing the fuel tank. Never add gasoline while the engine is running or still hot, as spilled or evaporated fuel may catch fire from engine sparks or muffler heat. Wipe off any spilled fuel before starting the engine and take care not to spill fuel.
- » Keep flammable items away from the vicinity of the exhaust port. Exercise caution with gasoline, matches, straw, and other flammable materials, as the exhaust port experiences high temperatures.

STARTING

Petrol Engine

1. Turn the STOP SWITCH clockwise to the "I" (ON) position (Fig-3).
2. Open the fuel cock (Fig-4).
3. Set the speed control lever 1/3 to 1/2 towards the high-speed position (Fig-5).
4. Close the choke lever. If the engine is warm or the ambient temperature is high, open the choke lever halfway or keep it fully open. If the engine is cold or the ambient temperature is low, close the choke lever fully (Fig-6).
5. Pull the starter handle slowly until resistance is felt; this is the "compression" point. Return the handle to its original position and pull swiftly. Do not pull out the rope all the way. After starting the engine, allow the starter handle to return to its original position while still holding the handle (Fig-7).

Diesel Engine

1. Turn the throttle lever to the START position (open by about 30 degrees) (Fig-5-D).
2. By pulling the starter knob slowly, reach a point where resistance becomes strong (compression point). Pull it further to find a point where resistance is reduced. Return the knob, but slowly return it to its original position (Fig-7-D).

CAUTION

Do not pull the rope all the way, and do not release your hand from the pulled knob. Slowly return it to the original position.

Warm-Up Procedure: After starting the engine, ensure to conduct a warm-up run for 2 to 3 minutes. This step is crucial and should be performed without fail, especially during the winter season.

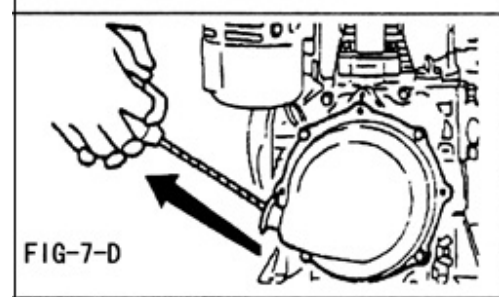
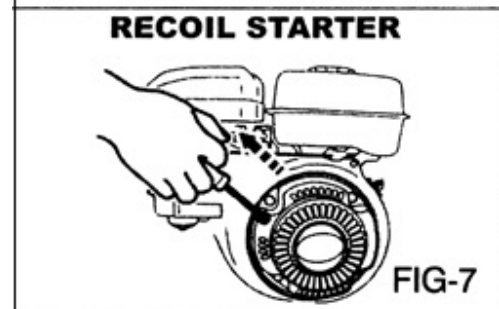
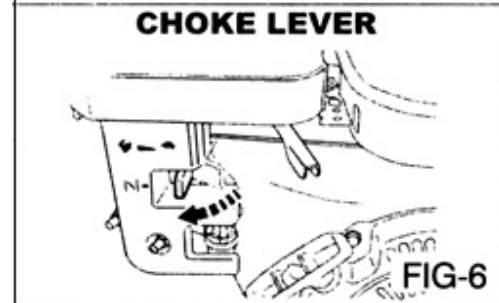
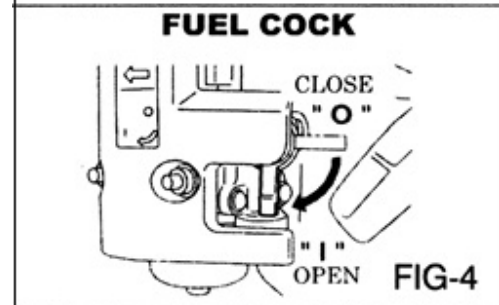
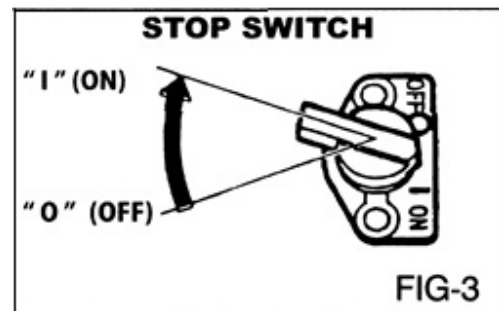

OPERATION

1. As the engine warms up, gradually move the choke lever to the OPEN position (Fig-8).

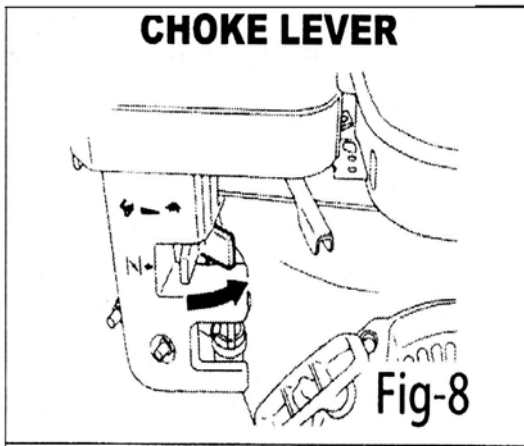

2. Move the speed control lever from LOW to HIGH position. When the engine speed reaches approximately 2,300-2,600 RPM, the centrifugal clutch engages. If the engine speed increases very slowly, there is a possibility that the clutch can slip. Do not operate the speed control lever slowly (Fig-9,10).

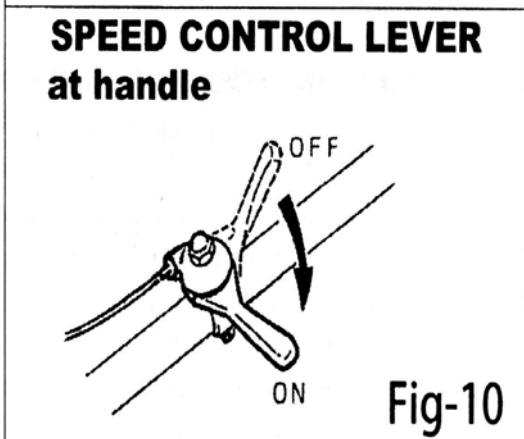

3. The Oil Alert system is designed to prevent engine damage caused by an insufficient amount of oil in the crankcase. Before the oil level in the crankcase falls below a safe limit, the Oil Alert System will automatically stop the engine (the engine switch will remain in the ON position).

CAUTION

If the engine stops and will not restart, check the engine oil level.

4. When compacting asphalt, it is advisable to paint the bottom face of the vibrating plate with diesel fuel. This will assist in preventing the plate from sticking to the asphalt.
5. When shutting off the vibrator, turn the speed control lever from the HIGH to LOW position. Do not move the speed control lever slowly.

TRANSPORTATION

1. Be sure to stop the engine while transporting.
2. Screw up the fuel tank cap securely and close the fuel valve to avoid fuel leaking.
3. In transportation by car, fix the machine securely to prevent it from moving or falling down. In case of driving for a long distance or on rough terrain, take out fuel from the tank.

SHUTDOWN

Emergency Engine Stop

1. To stop the engine in an emergency, turn the stop switch to the OFF position.

Normal Engine Stop

Under normal conditions, use the following steps:

1. Set the speed control lever at the low speed and allow the engine to run at low speed for 2 or 3 minutes before stopping (Fig-11).
2. Turn the stop switch to the OFF position (Fig-12).
3. Close the fuel cock (Fig-13).

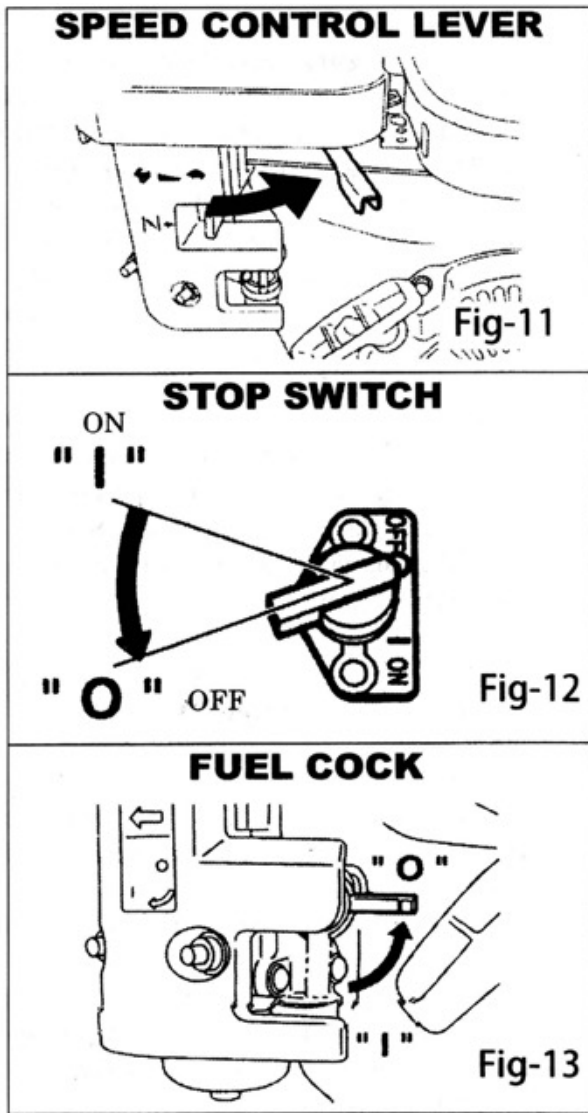

SERVICE&STORAGE

CAUTION

- » Stop the engine and do not smoke or allow work in the immediate area when refueling. Fire or explosion could result from flames or sparks.
- » Shutdown the engine before performing service or maintenance. Contact with moving parts can cause serious injury.
- » Allow the machine and engine to cool before performing service or maintenance. Contact with hot components can cause serious burns.

Daily

- » Remove mud, dirt, etc., from the unit.
- » Clean the bottom face of the vibrating plate.
- » Check the air cleaner element and clean if necessary.
- » Check all nuts, bolts, and screws for tightness and re-tighten as necessary.

Weekly

AIR CLEANER SERVICE (Fig-14): Dirty air cleaner elements can cause starting difficulty, power loss, engine malfunctions, and shorten engine life significantly. Keep the air cleaner element clean.

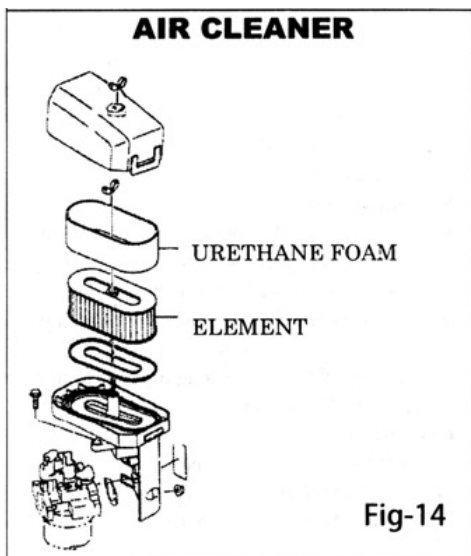

URETHANE FOAM ELEMENT:

- » Remove the element and wash it in kerosene or diesel fuel.
- » Saturate it in a mixture of 3 parts kerosene or diesel fuel and 1 part engine oil.
- » Squeeze the element to remove the mixture and install it in the air cleaner.

URETHANE FOAM DUAL STRUCTURE:

- » Clean the urethane foam in the same way as described above.
- » Wash the element in kerosene or diesel fuel.

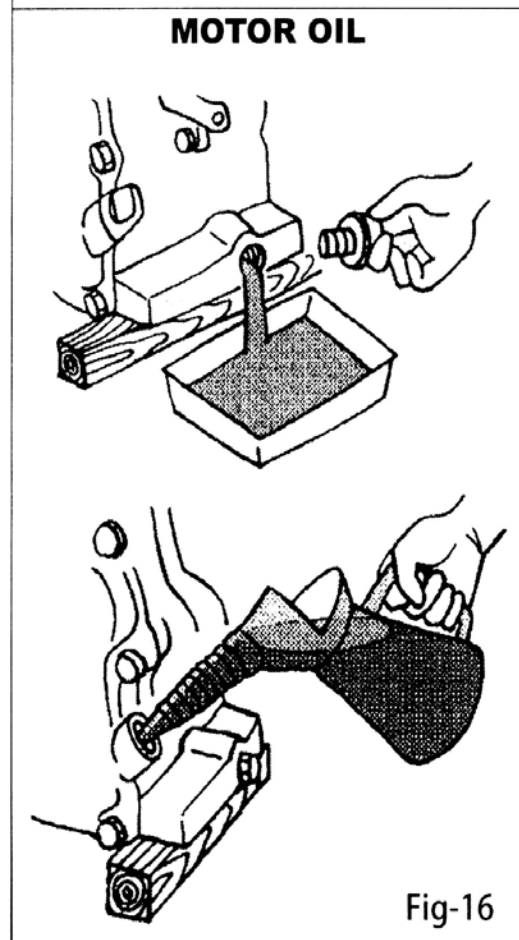
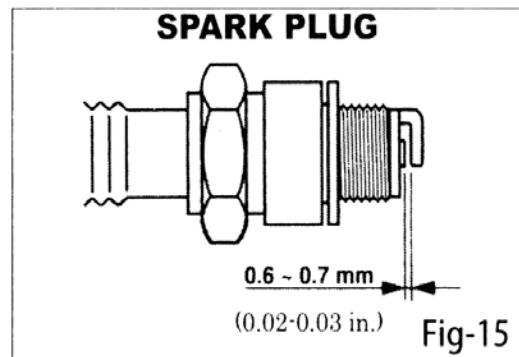

- » Saturate it in a mixture of 3 parts kerosene or diesel fuel and 1 part engine oil.
- » Shake off excessive oil. B. Remove spark plug, clean and adjust the spark plug gap to 0.6-0.7mm (0.02-0.03 in.) (Fig-15). C. Drain the motor oil of the engine and replace it with new specified oil (Fig-16).

NOTE: When the engine is new, the first oil change must be made after 20 hours of operation, and replenish the oil tank before operating.

Monthly

Change the oil in the vibrator assembly.

Storage

When storing the compactor for long periods after operation:

- » Thoroughly drain the fuel from the fuel tank, fuel pipe, and carburetor.
- » Pour a few drops of motor oil into the cylinder by removing the spark plug.
- » Rotate the engine several times by hand so that the cylinder interior is covered with oil.
- » Clean the outer surface of the machine with an oil-moistened cloth.
- » Cover the unit and store it in a humidity-free area.

MAINTENANCE

1. Check the oil level in the motor crankcase daily.
2. Check the vibrator oil level weekly.
3. Inspect the rubber anti-vibration mounts for wear or deterioration.
4. Clean the underside of the plate regularly to prevent a build-up of material.

SERVICE

1. Change the oil in the motor crankcase regularly to minimize wear.
2. Inspect, clean, and/or replace the motor air cleaner regularly, especially when operating in a dusty environment.
3. Inspect, clean, and/or replace the spark plug regularly.
4. Check all fasteners for tightness regularly due to the machine's vibration.
5. Check V-belt tension, wear, and ensure it is running true. Adjust or replace as required.

Vibrator Oil Check:

1. Place the plate compactor horizontally on a flat surface, ensuring it is level during the oil check.
2. Check the vibrator oil level by removing the plug (vibrator oil gauge) as shown in Fig-17. The oil level should be up to the oil plug. If oil is required, replace using SAE motor oil, as suggested in the table (Fig-1).
3. When changing the vibrator oil, remove the drain plug (Fig-17) and tip the compactor to drain the oil, noting that the oil will drain more easily when hot.

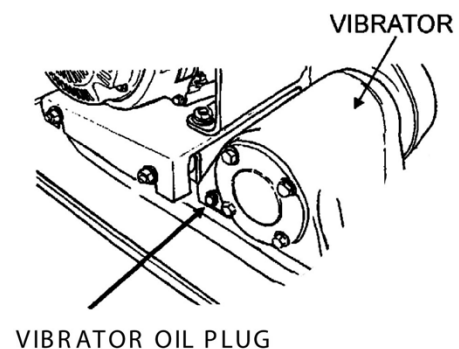

Fig-17 Vibrator Oil Plug

TROUBLESHOOTING

| SYMPTOM | POSSIBLE CAUSES AND CORRECTION |
|---------------------------|-------------------------------------------------------------------------------------------------------------------------------------------------------------------------------------------------------------------------------------|
| Motor Fails to Start | Verify ON/OFF Switch Position: Ensure the ON/OFF switch is set to the 'ON' position. Confirm that the switch is functioning correctly. |
| | Examine Fuel Supply: Check the fuel tank to ensure an adequate and clean fuel supply. Inspect for clogs or blockages in the fuel line that may hinder fuel flow. |
| | Check Crankcase Oil Level (For Honda or Kama Motors): Inspect the crankcase oil level, especially for Honda or Kama motors. These motors may have an oil sensor device that prevents starting when oil levels are low. |
| | Inspect Carburetor Jet and Bowl: Ensure the carburetor is free from debris or obstructions. Clean the carburetor jet and bowl to guarantee proper fuel mixing. |
| Motor Suddenly Stops | Fuel Supply Issues: Check the fuel tank to ensure an adequate and clean fuel supply. Inspect for any blockages or clogs in the fuel line that may disrupt the fuel flow. |
| Petrol Motor Lacks Power | Air Filter Condition: Inspect the air filter for dirt, dust, or debris. If the air filter is dirty or clogged, it can restrict airflow to the engine, resulting in decreased power. |
| Insufficient Vibration | Drive Belt Condition: Check for a slipping or missing drive belt. A worn or damaged drive belt can lead to insufficient vibration. |
| Machine Not Moving Freely | Build-Up of Material: Check the underside of the plate for a build-up of material. |

REPLACEMENT PARTS LIST

Bearings: The machine utilises sealed bearings for specific components:

- » Centrifugal Clutch: Grease lubricated.
- » Vibrator: Oil bath lubricated.

Finish: The overall finish of the machine is achieved with the following coatings:

- » Machine Body: Gold equipment enamel.
- » Handle: Black-backed enamel.
- » Exposed Metal Surface: Zinc electroplated for corrosion protection.

MAJOR COMPONENTS

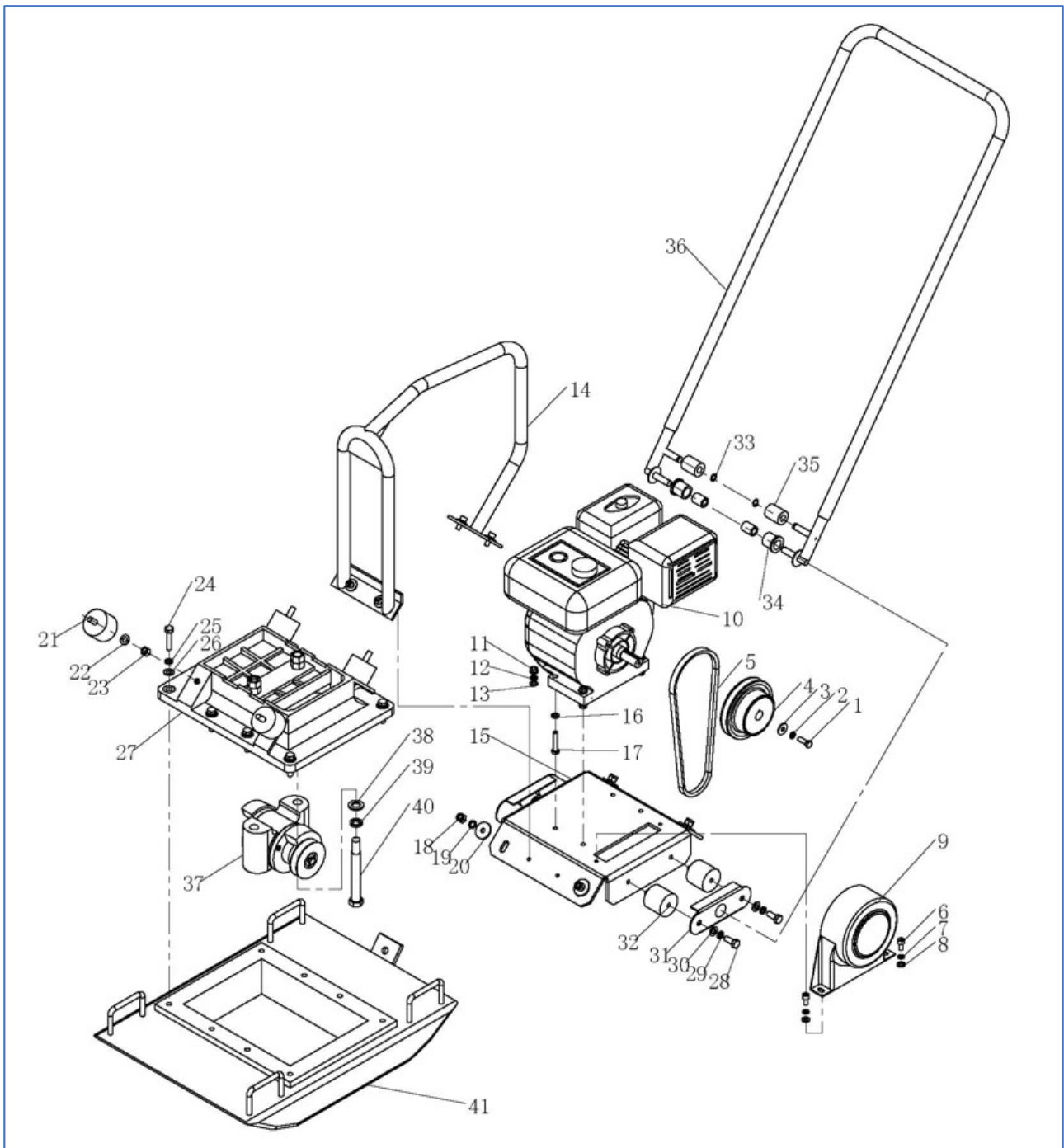

| PART NO. | DESCRIPTION | QYT |
|-----------|------------------------------------|-----|
| CNP200001 | Socket head bolt M8*30 | 1 |
| CNP200002 | Spring washer φ8 | 1 |
| CNP200003 | Bigger flat washer φ8 | 1 |
| CNP200004 | Clutch assembly | 1 |
| CNP200005 | Belt | 1 |
| CNP200006 | Socket head bolt M8*20 | 2 |
| CNP200007 | Spring washer φ8 | 2 |
| CNP200008 | Flat washer φ8 | 2 |
| CNP200009 | Belt cover | 1 |
| CNP200010 | Engine | 1 |
| CNP200011 | Locknut M8 | 4 |
| CNP200014 | Protective frame(Optional) | 1 |
| CNP200015 | Plate for engine mounting | 1 |
| CNP200016 | Bigger flat washer φ8 | 4 |
| CNP200017 | Hex bolt M8*40 | 4 |
| CNP200018 | Locknut M10 | 4 |
| CNP200019 | Spring washer φ10 | 4 |
| CNP200020 | Bigger flat washer φ10 | 4 |
| CNP200021 | Shock absorber for vibrating plate | 4 |
| CNP200022 | Flat washer φ10 | 4 |
| CNP200023 | Nut M10 | 4 |

| PART NO. | DESCRIPTION | QYT |
|-----------|---------------------------------|-----|
| CNP200024 | Hex bolt M12*45 | 8 |
| CNP200025 | Spring washer φ12 | 8 |
| CNP200026 | Flat washer φ12 | 8 |
| CNP200027 | Vibrator support | 1 |
| CNP200037 | Vibrator assembly | |
| CNP200028 | Hexagonal bolt M10 | 4 |
| CNP200029 | Spring washer φ10 | 4 |
| CNP200030 | Flat washer φ10 | 4 |
| CNP200031 | Plate, handle setting | 2 |
| CNP200032 | Shock absorber for handle | 4 |
| CNP200033 | Circlip φ12 | 2 |
| CNP200034 | Rubber coupling for handle | 2 |
| CNP200035 | Rubber ring for handle | 2 |
| CNP200036 | Straight handle Assy | 1 |
| | Foldable handle Assy (Optional) | 1 |
| CNP200038 | Flat washer φ18 | 2 |
| CNP200039 | Spring washer φ18 | 2 |
| CNP200040 | Fit bolt M16*150 | 2 |
| CNP200041 | Vibrating plate | 1 |

VIBRATOR ASSY

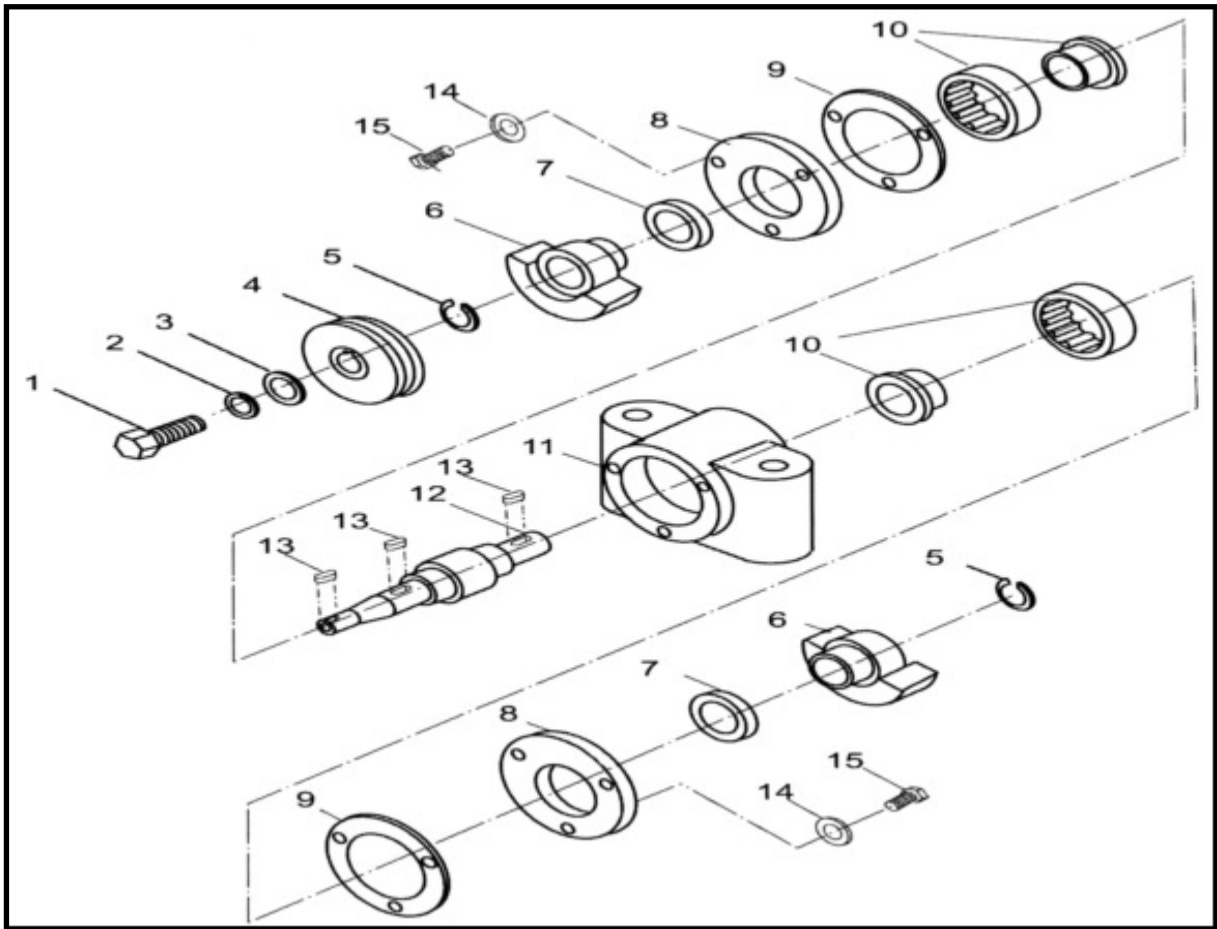

| PART NO. | DESCRIPTION | QYT |
|-----------|------------------------|-----|
| 200037-01 | Socket head bolt M8*20 | 1 |
| 200037-02 | Spring washer φ8 | 1 |
| 200037-03 | Flat washer φ8 | 1 |
| 200037-04 | Driven pulley | 1 |
| 200037-05 | Circlip φ24 | 2 |
| 200037-06 | Ecc. rotator | 2 |
| 200037-07 | Oil seal 35*52*7 | 2 |
| 200037-08 | Case cover/pulley | 2 |
| 200037-09 | Paper cushion | 2 |
| 200037-10 | Bearing 42306 | 2 |
| 200037-11 | Bearing seat | 1 |
| 200037-12 | Main shaft | 1 |
| 200037-13 | Flat key | 3 |
| 200037-14 | Spring washer φ6 | 6 |
| 200037-15 | Socket head bolt M6*25 | 6 |



BIGGER BOYZ TOYZ
COMMERCIAL

BBTA.COM.AU

Copyright © Bigger Boyz Toyz Australia

Unit 2/3 Delta Place Albion Park Rail NSW 2527 • 02 4257 4787

