

OWNER'S MANUAL

Assembly & Operating Instructions

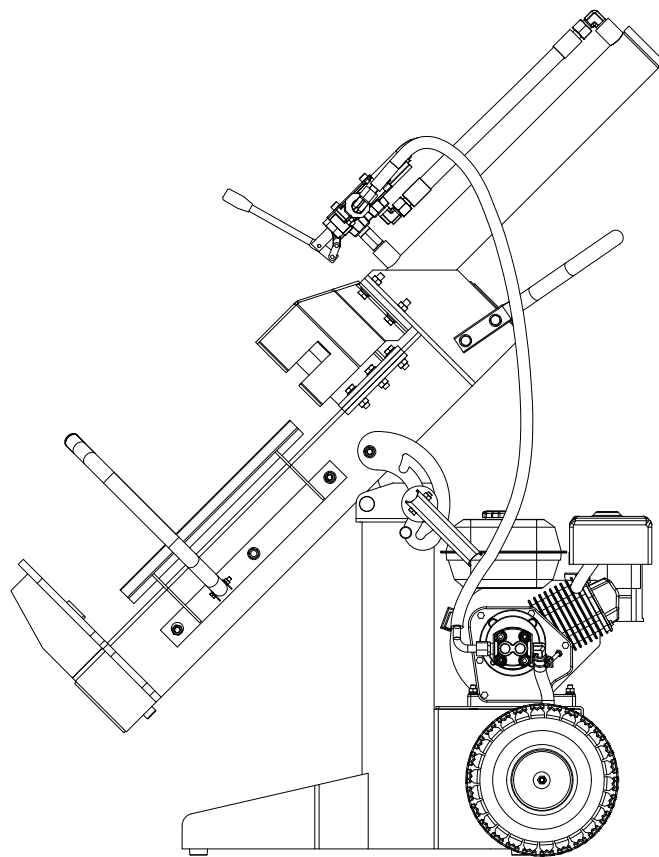

LOG SPLITTER 12/20T

Vertical & Horizontal



Thank you for choosing our equipment. It was carefully engineered to provide excellent performance when properly operated and maintained.

Please read this entire manual before operating the equipment. It instructs you on how to set up, operate, and maintain your equipment safely and easily. Ensure that you and any other persons operating the equipment carefully follow the recommended safety practices at all times, as failure to do so could result in personal injury or property damage.

All information in this manual is relevant to the most recent product information available at the time of printing. Review this manual frequently to familiarise yourself with the equipment, its features, and operation. Please note that this Owner's Manual may cover a range of product specifications for various models. Characteristics and features discussed and/or illustrated in this manual may not be applicable to all models. We reserve the right to change product specifications, designs, and equipment without notice and without incurring obligation.

All the power testing information used to establish the power rating of the engine equipped on this equipment can be found in the engine manufacturer's manual or website. If you encounter any problems or have questions about the equipment, please contact our Customer Support Department.

Throughout this manual, all references to the right and left side of the equipment are observed from the operating position. The engine manufacturer is responsible for all engine-related issues concerning performance, power-rating, specifications, warranty, and service. Refer to the engine manufacturer's Owner's Manual, packed separately with your equipment, for more information.

Customer Support

Before initiating a product return, kindly reach out to our dedicated Customer Support Department at Bigger Boyz Toyz. We are here to assist you.

Phone: 02 4257 4787

Email: bbt@bbta.com.au

Warehouse: Unit 2/3 Delta Place, Albion Park Rail NSW 2527

If you have difficulty assembling the product or have any questions about the controls, operations, or maintenance of the equipment, please don't hesitate to get in touch with our Customer Support Department.

CONTENTS

SAFETY & ALERT SYMBOLS	4
FOR YOUR SAFETY AND THE SAFETY OF <u>OTHERS!</u>	4
ADDITIONAL INFORMATION AND POTENTIAL CHANGES	4
HAZARDS SYMBOLS	5
GENERAL SAFETY	6
OPERATION SAFETY	6
TRANSPORTING SAFETY	6
MAINTENANCE SAFETY	6
ADDITIONAL HAZARDS	6
STORAGE SAFETY	7
OPERATOR ZONE AND SAFETY	7
LOG LOADING AND SPLITTING	7
GENERAL INFORMATION	8
APPLICATION	8
ASSEMBLY	9
OPERATION	22
TIPS FOR SPLITTING LOGS NOT CUT SQUARE	22
PRE-OPERATION CHECK	23
OPERATION	24
MAINTENANCE	25
ENGINE MAINTENANCE	26
TYRE PRESSURE	26
HYDRAULIC FLUID MAINTENANCE	26
BEAM AND SPLITTING WEDGE MAINTENANCE	26
OFF-SEASON STORAGE	26
TROUBLESHOOTING	27
SPECIFICATION	27
REPLACEMENT PARTS LIST	28

SAFETY & ALERT SYMBOLS

FOR YOUR SAFETY AND THE SAFETY OF OTHERS!



Safety precautions should be followed all the time when operating this equipment. Failure to read and understand the Safety Messages and Operating Instructions could result in injury to yourself and others.



This Operating Instructions has been developed to provide complete instructions for the safe and efficient operation of this equipment. Refer to the engine manufactures instructions for data relative to its safe operation.



WARNING: Read and thoroughly understand all instructions in this equipment and on the safety decals before assembling or operating this equipment. Failure to do so may cause serious injury or death. Do not allow anyone to operate this equipment who has not read this manual. As with all power equipment, this equipment can be dangerous if assembled or used improperly. Do not operate this equipment if you have any questions concerning its safe operation. Contact our Customer Support Department for assistance in addressing any queries or concerns.

This SAFETY ALERT SYMBOL identifies important safety messages in this manual. Failure to follow this important safety information may result in serious injury or death.



DANGER indicates a hazardous situation which, if not avoided, will result in serious injury or death.



WARNING indicates a hazardous situation which, if not avoided, could result in serious injury or death.



CAUTION indicates a hazardous situation which, if not avoided, could result in minor or moderate injury.

ADDITIONAL INFORMATION AND POTENTIAL CHANGES

We reserve the right to discontinue, change, and improve our products at any time without notice or obligation to the purchaser. The descriptions and sections contained in this manual were in effect at the time of printing. Equipment described within this manual may be optional. Some illustrations may not be applicable to your equipment.

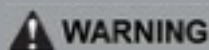















Your Responsibility—Restrict the use of this equipment to persons who have read, understood, and will follow the warnings and instructions in this manual and on the machine

SAVE THESE INSTRUCTIONS!

HAZARDS SYMBOLS

Potential hazards associated with the operation of this equipment will be referenced with Hazard Symbols which appear throughout this manual.

	READ THE OWNER'S MANUAL(S) : Read, understand and follow all instructions in the manual(s) before attempting to assemble and operate.
	FACE PROTECTION : Always wear safety goggles or safety glasses with side shields or a face shield when operating this equipment as well as ear protection.
	WEAR GLOVES : Always wear non-slip, heavy-duty protective gloves when operating this equipment.
	WEAR SAFETY FOOTWEAR : Always wear non-slip steel-toed safety footwear when operating this equipment.
	BEWARE OF ROTATING BLADES : This equipment has a rotating cutting blade capable of amputating hands and feet and throwing objects. Keep hands and feet out of openings while machine is running. Failure to observe these safety instructions could result in serious injury or death.
	BEWARE OF FLYING OBJECTS : Beware of thrown objects, which can ricochet causing serious injury to the eyes. Always wear eye & ear protection when operating.
	Never wear loose clothes or long jewellery and keep your long hair secured when operating this equipment. Never operate this equipment in bare feet or sandals.
	CARBON MONOXIDE AND GAS : Exhaust contains poisonous carbon monoxide, a colourless and odourless gas. Breathing exhaust fumes can cause loss of consciousness and may lead to death.
	RESPIRATORY HAZARDS : ALWAYS wear approved respiratory protection when required.
	PETROL OIL : Petrol is extremely flammable and the vapours are explosive. Serious personal injury can occur when petrol is spilled on you or your clothing, which can ignite. In the event of a petrol spill, wash your skin and change clothes immediately.
	BURN HAZARDS : Engine components can produce intense heat. To avoid burns, DO NOT touch these areas while the engine is running or right after operations. Never operate the engine with removed heat shields or guards.
	BYSTANDERS : Keep bystanders, helpers, pets, and children at least 10m from the equipment while it is in operation. Stop equipment if anyone enters the area.
	SINGLE OPERATOR : Only one person should operate the equipment at a time. The adult who loads and stabilises the log must be the person who operates control handle.
	DO NOT use in the rain.

GENERAL SAFETY

- » **Age Requirement:** Do not allow operation by persons under 18 years of age.
- » **Protective Clothing:** Always wear protective clothing, including shatterproof glasses and steel-toed boots.
- » **Health Check:** Do not operate if you are unwell, fatigued, or under the influence of drugs or alcohol.
- » **Proper Protection:** Use respiratory masks, hearing, and eye protection.
- » **Decal Visibility:** Replace any unreadable safety decals or nameplates.
- » **Attachments:** Use only recommended accessories to prevent damage or injury.
- » **High Temperatures:** Let the engine cool before refuelling or servicing. Never touch hot components like the exhaust manifold.
- » **Ventilation:** Refuel in well-ventilated areas, away from open flames.
- » **Explosive Atmospheres:** Avoid operating near combustible materials.
- » **Unattended Operation:** Stop the engine if leaving the equipment unattended.
- » **Maintenance:** Keep the equipment in safe operating condition. Service air filters and check all bolts before use.

OPERATION SAFETY

- » **Safety Features:** Ensure all guards and safety devices are attached and functional.
- » **Environment:** Operate in open, well-lit areas on flat, solid ground. Block wheels to prevent movement.
- » **Handling Logs:**
 - » Place hands on the sides of the log, never on the ends. Do not use feet or objects to stabilise logs.
 - » For logs which are not cut square, place the least square end toward the beam and wedge, and the square end toward the end plate.
 - » NEVER try to split two logs on top of each other.

- » NEVER try to cross split a log.
- » **Splitting Position:** Lock beam horizontally or vertically. For vertical splitting, ensure logs are stabilised against the beam.
- » **Safety Precautions:** Keep hands away from moving parts and never attempt to operate the controls with your feet.

TRANSPORTING SAFETY

- » **Cargo:** Do not carry passengers or cargo on the log splitter.
- » **Towing:** Use a Class I, 2 inch (50mm) towing ball and secure the splitter properly with safety chains. Do not exceed 60 km/h when towing.
- » **Preparation:** Turn the fuel shut off valve to "OFF" before towing.

MAINTENANCE SAFETY

- » **Pre-service Checks:** Disconnect the spark plug and relieve hydraulic pressure before servicing.
- » **Hydraulic System:** Check for leaks with cardboard and replace damaged components. Never check leaks with hands.
- » **Oil Levels:** Always check hydraulic and engine oil levels before operation.
- » **Professional Assistance:** Seek immediate medical help if injured by hydraulic fluid and only allow qualified technicians to adjust hydraulic settings.

ADDITIONAL HAZARDS

- » **Environmental Check:** Ensure no hazardous utilities are in the operating area.
- » **Noise:** Use hearing protection to prevent potential hearing loss from noise exposure.
- » **Vibration:** Be cautious of repetitive motions and vibrations which could affect hands and arms.

Remember: Always keep the work area clean and free of obstructions. Never operate the equipment if it's in poor condition or without proper safety training and preparation.

STORAGE SAFETY

- » **Cleanliness:** Always clean debris and chaff from the engine and muffler areas to prevent fires.
- » **Cooling Period:** Allow the equipment to cool for at least ten (10) minutes before storing.
- » **Fuel Management:** Always drain the fuel tank prior to storage to eliminate potential fire hazards.
- » **Proper Location:** Store equipment in a clean, dry location out of the reach of children.
- » **Maintenance Checks:** Ensure all safety features are intact and the equipment is in good repair before storing.

OPERATOR ZONE AND SAFETY

- » **Designated Operator Zone:** ONLY operate the log splitter from the designated operator zone, as illustrated in the equipment diagrams. This zone provides the safest and most efficient access to the control valve and the beam.
- » **Exclusive Access:** Ensure that no other individuals are within the work zone while operating the log splitter to prevent serious accidents.

LOG LOADING AND SPLITTING

1. **Log Placement:** Load a log onto the beam, positioning it against the end plate.
2. **Clearance:** Always ensure hands and other body parts are clear of crush hazard zones before and during operation.
3. **Splitting Operation:**
 - » To split the log, firmly push the control valve handle FORWARD using both hands.
 - » To retract the wedge to its starting position, pull the control valve handle BACKWARD using both hands.
4. **Post-Splitting:** After the log is split, promptly clear the split wood from the work zone to maintain a clean and safe area.

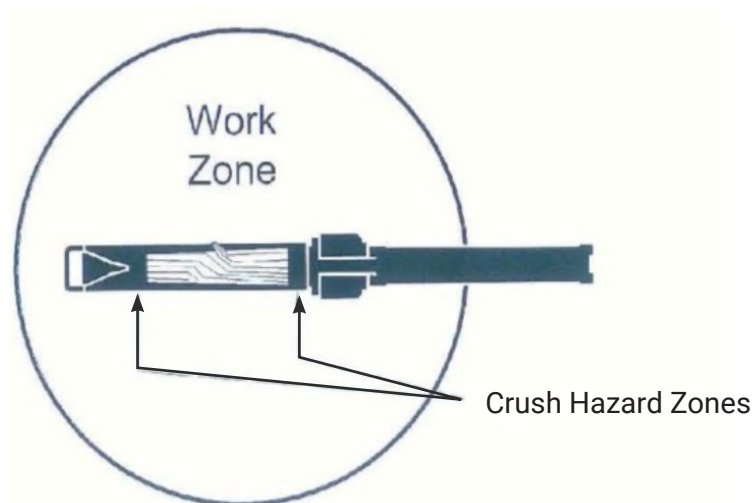

GENERAL INFORMATION

APPLICATION

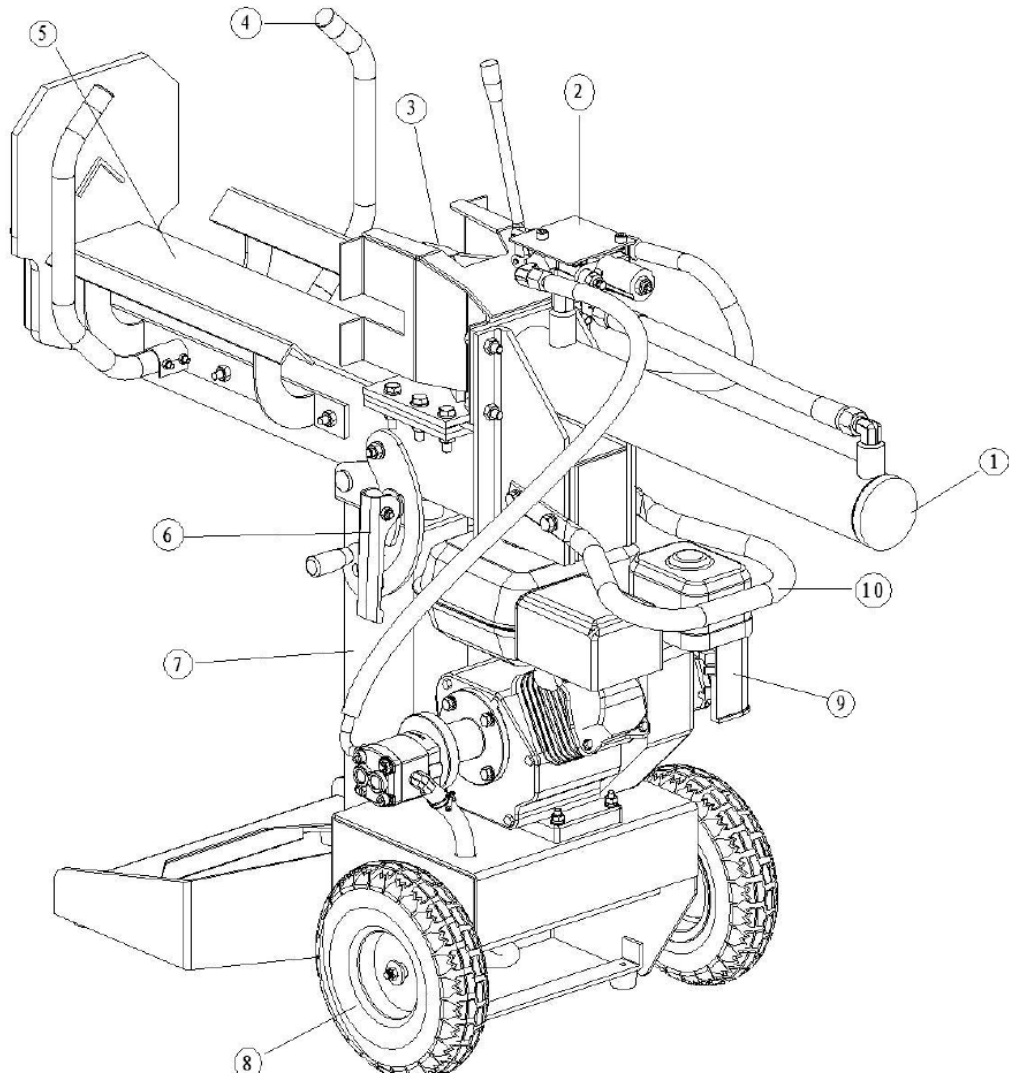

- | | |
|--------------------------|--------------------|
| 1. Hydraulic Cylinder. | 6. Lock Assemble. |
| 2. Control Valve Handle. | 7. Main Body. |
| 3. Wedge. | 8. Wheel. |
| 4. Log Guide &Guard | 9. Engine Assemble |
| 5. Beam. | 10. Handle. |

ASSEMBLY

Step 1: Unbox, unwrap, and lay out all parts

When you first get your log splitter it will be boxed and wrapped in clear wrap, to make sure everything was received the best thing to do is unbox, unwrap, and lay out all the parts for the log splitter.

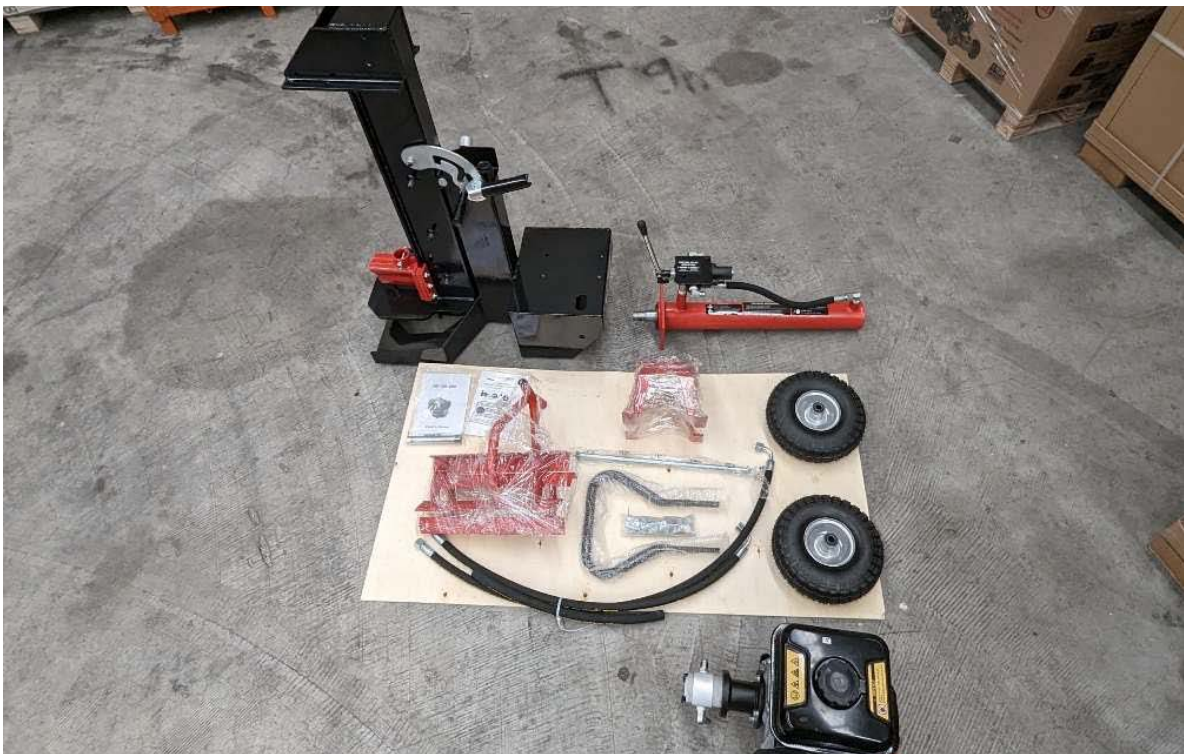

Step 2: Lay out all bolts, washer, and nuts

When you receive your log splitter all the bolts, washers and nuts will be in one package. To make sure you have received all your bolts, washers and nuts it is best to lay them out. This also makes it easier to find them when assembling.



Step 3: Oil tank and wheels

When assembling your log splitter, the first part you start with is the oil tank and wheels. The wheel axle slides through the base of the oil tank and the wheels slip on both sides. Then you can tighten up the wheel retaining nut.



Step 4: Attach engine to engine bracket

Your engine will sit on the engine support bracket with the pump facing the pivot bracket side of the Log splitter. When bolting your engine please be sure to use the 4 long bolts with the spring washers provided.



Step 5: Attach hydraulic feed line

The hydraulic feed line will attach under your engine bracket and be fed through and onto your hydraulic pump. This line will be secured using Hose clamps that will need to be put on the hose before it is pushed onto the tank and pump spigot fittings.



Step 6: Attaching your wedge to the ram

Your wedge will need to be bolted to your ram before it is bolted in place as you will not be able to get the bolt in place after the ram is bolted in place.



Step 7: Attaching hydraulic ram and wedge protector

Your Ram in the box will be loosely sitting on the I-beam and need to be bolted in place. This is held in place with 4 bolts. These 4 bolts will also hold your wedge protector in place and will go through the wedge protector into the ram then through the bracket on your I-beam.



Step 8: Attach hydraulic hoses

Your log splitter will need the hydraulic high pressure feed hose (Hydraulic pump to control valve) and hydraulic return hose (control valve to hydraulic tank) attached. The longer of the two hoses will run from your hydraulic pump to your control valve and the shorter hose will run from the control valve to the tank return fitting.





Step 9: Attach handle

Your log splitter comes with a handle that helps you move the log splitter around. This handle is held in with 4 bolts with washers and spring washers.

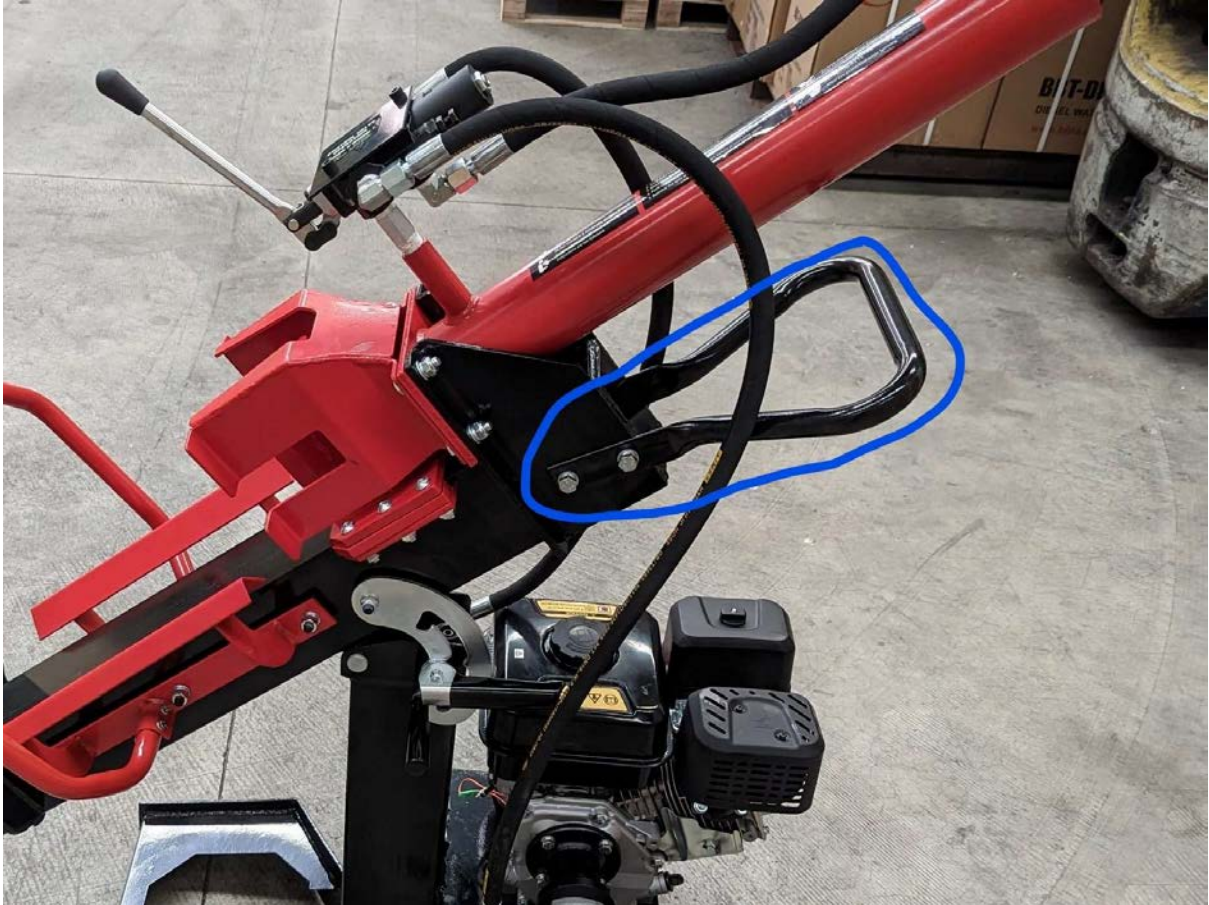

Step 10: Adding oil to your engine

Now that your log splitter is built you will need to add oil to your engine. These log splitters come with a JD 6.5hp engine. This engine takes 600ml of SAE30 oil. Before adding the oil, please make sure your engine is sitting level. Please note a good indicator that your engine oil is full is to fill it to the level of the threads where the dipstick screws in.



Step 11: Adding hydraulic oil to your machine

After engine oil has been added to your engine you will need to add your hydraulic oil. Our 12/20T Vertical/Horizontal log splitter holds 6 liters. We recommend the use of ISO68 hydraulic oil.

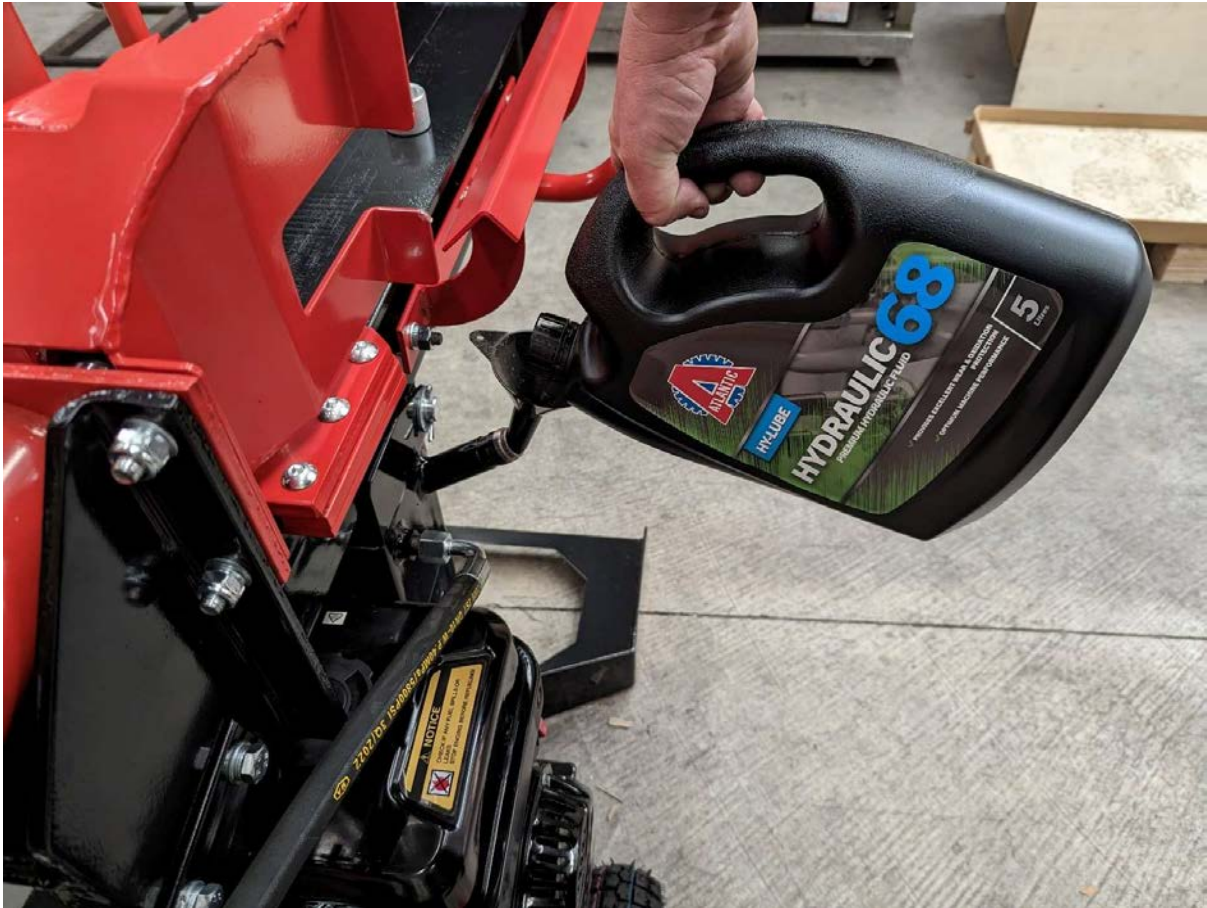

Step 12: Adding fuel and starting your machine

After your engine oil and hydraulic oil are full, you will need to start the machine without the silver hydraulic oil tank cap on. Move your ram back and forth using the control valve to prime and bleed out any air from your hydraulic system. After this is done, reinstall your oil cap. Your machine is now ready for use. (Please note after your machine is switched off, this is a good time to check all your fittings for any hydraulic leaks)



OPERATION

TIPS FOR SPLITTING LOGS NOT CUT SQUARE

1. **Identify Ends:** Determine which end of the log is less square. This might be the end with more of an irregular shape or more angular cuts.
2. **Positioning the Log:** Place the log on the splitter so that the less square (more irregular) end is towards the beam and wedge. This positioning helps in utilising the natural force of the wedge penetrating the uneven end, potentially making the splitting process smoother.
3. **Square End Placement:** Position the more square (regular) end towards the end plate of the log splitter. This end typically provides a more stable base against the end plate, allowing for better overall stability during the splitting process.
4. **Ensure Stability:** Before splitting, ensure the log is stable on the beam. If the log wobbles or shifts, use wooden shims or small pieces of wood to stabilise it. This is crucial for safety and effectiveness.
5. **Operate Carefully:** Proceed with splitting the log by operating the control valve handle. As always, ensure that your hands and all other body parts are well clear of the moving parts.
6. **Reposition as Needed:** If the first split does not completely separate the log, reposition the remaining pieces according to their new shapes and repeat the splitting process. Remember to always position the least square ends towards the wedge.

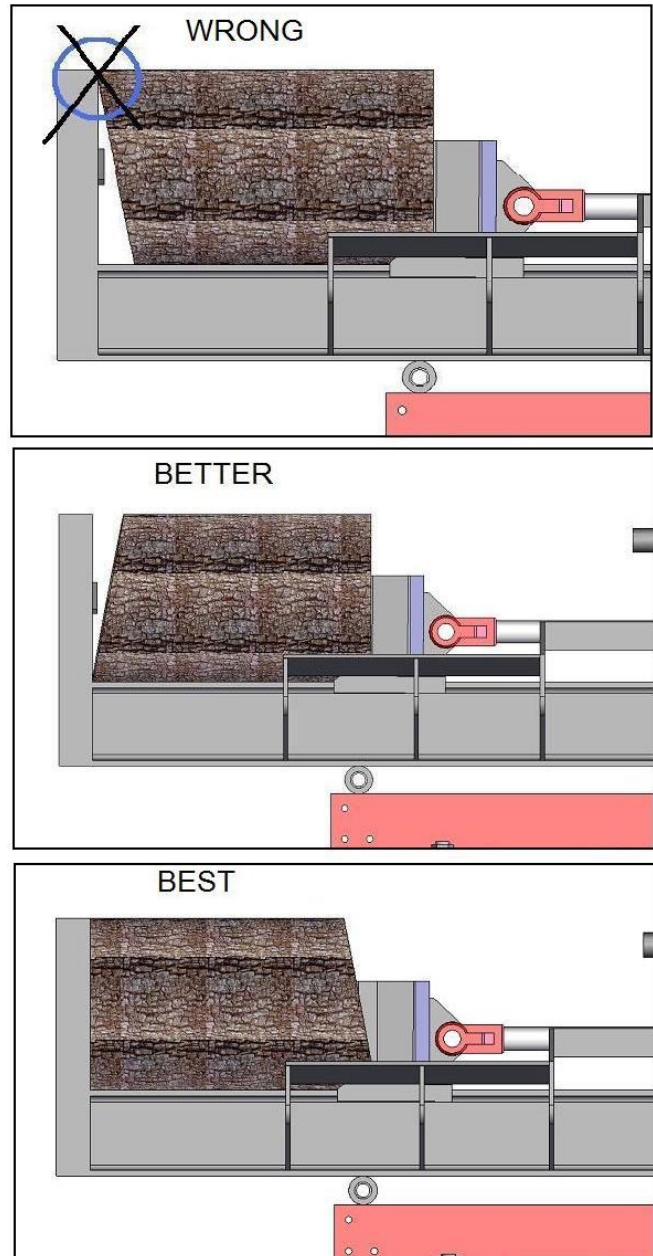

PRE-OPERATION CHECK

Engine Fuel and Oil

Before using your log splitter, it's important to properly fill it with fuel and oil:

1. **Check the Manual:** Refer to the engine manual for specific instructions on the type of petrol and engine oil suitable for your model.
2. **Engine Oil:**
 - » **Check Before Use:** Many log splitters are shipped without engine oil, so always check the oil level first.
 - » **Adding Oil:** Carefully fill the engine with oil, making sure not to overfill. Use the type and amount of oil specified in the manual.
3. **Adding Petrol:**
 - » Fill the petrol when the log splitter is either horizontal or vertical.

Hydraulic Oil Fill-Up

When you first receive your log splitter, you'll need to fill the hydraulic fluid reservoir, as it is shipped empty.

1. **Locate the Dipstick:** Find the vented reservoir dipstick next to the engine on top of the reservoir tank.

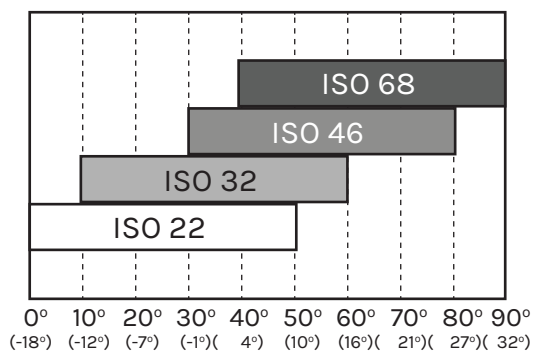

2. **Choose the Right Oil:**
 - » Check the outside temperature range where you'll use the log splitter.
 - » Use the provided chart to select the appropriate hydraulic oil.
 - » Recommended oil is Hydraulic oil ISO68.
 - » **Important:** Do not mix different types and grades of hydraulic oil/fluids.
3. **Fill the Reservoir:**
 - » Slowly add the hydraulic oil into the reservoir, watching the dipstick until the oil reaches the maximum line.
 - » Be careful not to overfill. Overfilling can cause leaks as the oil expands from the heat during operation.
4. **Cycle the Hydraulic System:**
 - » Start the engine.
 - » Use the control handle to move the wedge fully out and then back in, repeating this full cycle 12 times. This helps distribute the hydraulic fluid throughout the system.
 - » After cycling, turn off the engine and recheck the oil level.
5. **Final Check:**
 - » Ensure the oil level is above the minimum line on the dipstick and below the maximum. Add more oil if it's too low.
 - » Always check the hydraulic fluid level before each use to prevent damage to the hydraulic pump.

OPERATION

IMPORTANT: There is a vent plug on the right side of the machine. Before you begin your work, you should unscrew this plug about four turns to ensure proper air circulation in the oil tank. Remember to tighten the plug before transporting the machine to prevent oil leakage. If you leave the vent plug tightened while the machine is operating, the hydraulic movements may create excessive pressure, which can damage the machine.

1. **Starting the Engine:** Refer to the Engine Owner's Manual included with your log splitter for detailed instructions on how to start the engine.
2. **Positioning the Log:** Grasp the log from the sides and place it securely on top of the beam, resting against the end plate. Always align the log so that you are splitting it in the direction of the grain.
3. **Stabilising the Log:** Place your left hand on the side of the log to stabilize it.
4. **Splitting the Log:**
 - » Use your right hand to push the control handle lever forward to initiate the splitting.
 - » Remove your left hand from the log as soon as the wedge begins to make contact with the log.
 - » Continue holding the control handle in the forward position until the log is completely split.
5. **Handling the Split:**
 - » If you need to stop the wedge at any point due to unsafe conditions, release the control handle immediately.
 - » NEVER try to catch falling pieces of wood—let them fall safely to the ground.
6. **Retracting the Wedge:**
 - » Once the log is split, or the wedge is fully extended, promptly move the control handle to the reverse position to avoid damaging the hydraulic system and voiding your warranty.
7. **Removing the Wood:**
 - » Remove any partially split pieces from the wedge.
 - » For logs that are not fully split, position them for a second attempt, either from the opposite end or another section of the log.

MAINTENANCE

Proper maintenance is crucial for ensuring the safety and longevity of your log splitter. Follow these steps to safely put your log splitter into maintenance mode and perform necessary maintenance tasks:

1. Entering Maintenance Mode:

- » **Turn Off the Engine:** Ensure the engine is completely shut off before starting any maintenance work.
- » **Relieve Hydraulic Pressure:** Move the control valve handle forward and backward several times to relieve any built-up hydraulic pressure in the system. This step is essential for preventing accidental operation or hydraulic fluid spray during maintenance.

2. Performing Maintenance:

- » **Conduct Maintenance Tasks:** Perform the maintenance tasks as required, such as changing hydraulic fluid, checking hoses for wear or damage, and inspecting mechanical components for any signs of fatigue.
- » **Refer to Manuals:** Always refer to the engine owner's manual for specific maintenance instructions related to the engine. This manual will provide detailed guidance on tasks such as changing the engine oil, cleaning or replacing filters, and checking spark plugs.

3. Reassembling and Safety Checks:

- » **Reinstall Guards and Shields:** After maintenance, ensure all guards, shields, and other safety features are correctly reinstalled. These components are critical for safe operation, and their absence can lead to serious injuries.
- » **Safety Feature Check:** Conduct a thorough check to ensure that all safety features are functioning correctly. This includes testing safety switches, checking the integrity of protective coverings, and ensuring that all nuts and bolts are tightened to the correct specifications.

4. Post-Maintenance Testing:

- » **Run a Safety Test:** Once maintenance is complete and all parts are reassembled, perform a test run to ensure everything is operating smoothly. This test should be done in a controlled environment, where you can immediately shut down the equipment if something seems wrong.

5. Documentation:

- » **Record Maintenance:** Keep a log of all maintenance activities, including dates and details of the tasks performed. This record will help in scheduling future maintenance and can be important for warranty purposes.

What	When	How
Hoses	Each Use	Inspect for exposed wire mesh and leaks. Replace all worn or damaged hoses before starting engine.
Hydraulic Fittings	Each Use	Inspect for cracks and leaks. Replace all damaged fittings before starting engine.
Nuts and Bolts	Each Use	Check for loose bolts
Beam	Each Use	Apply grease to beam surface
Moving Parts	Each Use	Clear debris

ENGINE MAINTENANCE

- » **Consult Manual:** Always refer to the Engine Owner's Manual included with your log splitter for detailed instructions on engine maintenance, including checking and changing the engine oil.
- » **Oil Draining Precautions:** When draining engine oil, shield the hoses and frame to prevent oil spillage. After draining, clean any residual oil from the log splitter and hoses to prevent damage.

TYRE PRESSURE

- » **Type and Pressure:** The tires on your log splitter are designed for off-road use. The maximum recommended operating pressure is 30 psi.
- » **Safety Warning:** Never exceed the manufacturer's recommended tire pressure. Always maintain equal pressure in both tires to ensure even performance and reduce wear.

HYDRAULIC FLUID MAINTENANCE

- » **Regular Checks:** Before each use, check the hydraulic fluid level in the reservoir tank. Keep the fluid level within the specified range on the dipstick.
- » **Fluid Change Frequency:** Change the hydraulic fluid every 100 hours of operation. Follow these steps:
 1. **Drain Fluid:** Place an oil collection container under the tank. Remove the oil drain plug and let the fluid drain out. Note that the tank has a 6 liter capacity, but more fluid may be required due to fluid retention in the system's components.
 2. **Reattach and Refill:** After draining, reinstall the drain plug and tighten it. Refer to the Hydraulic Oil Fill-Up section to refill the reservoir, ensuring it is properly filled and that air is expelled from the system.
 3. **Check Level:** Always push the dipstick all the way down for an accurate reading.
- » **Disposal:** Dispose of used hydraulic fluid

and engine oil at an approved oil recycling centre.

- » **System Flushing:** When servicing the tank, pump, or valve, flush the system with kerosene to remove any contaminants that may damage hydraulic components.

BEAM AND SPLITTING WEDGE MAINTENANCE

1. **Lubrication:** Before each use, lubricate the top, sides, and bottom of the beam, as well as the areas where it comes into contact with the splitting wedge. Use engine oil for effective lubrication.
2. **Wedge Care:** Regularly inspect the wedge for dullness or nicks. If the wedge becomes dull or nicked, sharpen it to maintain efficient splitting performance.

OFF-SEASON STORAGE

If you plan not to use your log splitter for more than 30 days, follow these steps to prepare it for off-season storage:

1. **Engine Preparation:** Consult the Engine Owner's Manual provided with your log splitter for detailed instructions on how to prepare the engine for storage.
2. **Cleaning:** Clean the log splitter thoroughly to remove dirt, debris, and wood residue.
 - » **Avoid Water Pressure:** Do not use pressure washers or garden hoses for cleaning as they can damage the bearings or engine and shorten the equipment's life.
3. **Rust Prevention:** After cleaning, wipe the machine with an oiled rag, paying special attention to the wedge and the beam to prevent rust.
4. **Storage Location:** Store the log splitter in a clean, dry area away from corrosive materials such as fertilizer.
 - » **Ventilation Considerations:** If storing in an unventilated or metal storage shed, apply a light oil or silicone to rustproof the equipment. Using a log splitter cover is also recommended to protect against dust and moisture.

TROUBLESHOOTING

PROBLEM	SOLUTION
Cylinder rod will not move	SOLUTION: A, D, E, H, J
Slow cylinder shaft speed when extending or retracting	SOLUTION: A, B, C, H, I, K, L
Wood will not split or splits extremely slowly	SOLUTION: A, B, C, F, I, K
Engine bogs down during splitting	SOLUTION: G, L
Engine stalls under low load condition	SOLUTION: D, E, L, M

	CAUSE	SOLUTION
A	Insufficient oil to pump	Check oil level in oil tank
B	Air in oil	Check oil level in oil tank
C	Excessive pump inlet vacuum	Check pump inlet hose for blockage or kinks
D	Blocked hydraulic lines	Flush and clean the splitter hydraulic system
E	Blocked control valve	Flush and clean the splitter hydraulic system
F	Low control valve setting	Adjust control valve with a pressure gauge
G	High control valve setting	Adjust control valve with a pressure gauge
H	Damaged control valve	Return control valve for authorized repair
I	Internal control valve leak	Return control valve for authorized repair
J	Internal cylinder leak	Return cylinder for authorized repair
K	Internally damaged cylinder	Return cylinder for authorized repair
L	Engine Control out of adjustment	Adjust idle control nuts
M	Engine is loaded during idle down mode	Use shorter log length to allow engine to speed up before contact

SPECIFICATION

Ram force	12 Ton
Engine	6.5 HP
Gear Pump	2.1 GPM
Maximum Pressure	3500 PSI
Hydraulic Cylinder Size (bore x stroke)	3"x 19"
Cycle time	19 s
Hydraulic oil No.	ISO68
Hydraulic Tank Capacity	6 L
Max. Log opening	50 cm

REPLACEMENT PARTS LIST

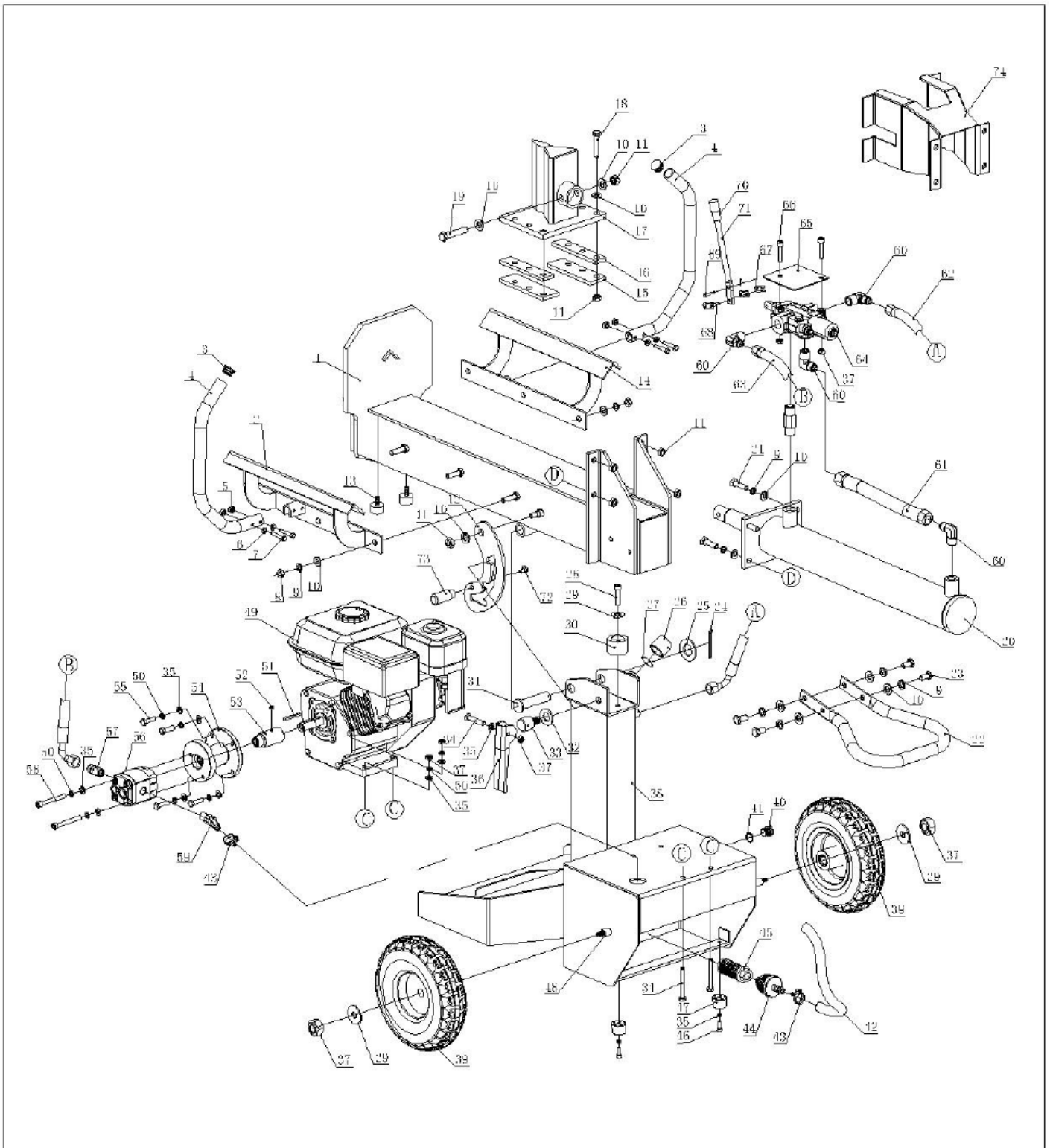

PART NO.	DESCRIPTION	QYT
1	BEAM	1
2	LOG GUIDER(LEFT)	1
3	TUBE GAP	2
4	LOG GUARD	2
5	M6 LOCK NUT	4
6	Φ6*φ12*1.5 WASHER	4
7	M6*40 BOLT	4
8	M10 NUT	6
9	Φ10 SPRING WASHER	14
10	Φ10*φ20*2 WASHER	27
11	M10 LOCK NUT	12
12	LOCK METAL PLATE	1
13	RUBBER ABSORBER	2
14	LOG GUIDER(RIGHT)	1
15	WEDGE PLATE	2
16	WEDGE SPACER	2
17	WEDGE	1
18	M10*45 BOLT	6
19	M10*65 BOLT	1
20	CYLINDER	1
21	M10*40 BOLT	4
22	HANDLE BAR	1
23	M10*16 BOLT	4
24	COTTER PIN φ4*36	1
25	Φ20*φ37*φ3 WASHER	1
26	OIL TANK GAP	1
27	O-RING 25*3.55	1
28	M8*50 SCREW	1
29	Φ8*φ24*2 WASHER	3
30	RUBBER ABSORBER	2
31	PIN	1
32	Φ14*φ37*φ3 WASHER	1
33	LOCK SHAFT	1
34	M8*40 BOLT	5
35	φ8 WAHSER	15
36	LOCK HANDLE	1
37	M8 LOCK NUT	9
38	BODY FRAME	1

PART NO.	DESCRIPTION	QYT
39	TYRE 10"	2
40	DRAIN BOLT M16*15	1
41	COMBINATION WASHER φ16	1
42	SUCTION TUBE	1
43	HOOP	2
44	INLET PIPE CONNECTOR	1
45	OIL FILTER	1
46	M8*20 BOLT	4
47	RUBBER FOOT	4
48	WHEEL SHAFT	1
49	ENGINE	1
50	Φ8 SPRING WASHER	10
51	FLAT KEY	1
52	SCREW M8*6	1
53	SHAFT CONNECTOR	1
54	SHAFT CONNECTOR SEAT	1
55	M8*30 BOLT	4
56	PUMP CONNECTOR	1
57	CONNECTOR 3/8-M18*1.5	1
58	M8*90 BOLT	2
59	OIL PUMP CONNECTOR	2
60	1/2 -M18 *1.5 CONNECTOR	4
61	OIL TUBE B	1
62	OIL TUBE A	1
63	OIL TUBE C	1
64	CONTROL VALVE	1
65	UPPER PLATE	1
66	M8x40 BOLT	2
67	CHAIN PLATE LOCK	1
68	CHAIN PLATE	1
69	PIN 5X25B	1
70	PLASTIC COVER	1
71	CONTROL HADLE	1
72	M6*10 SCREW	1
73	HANDLE BAR	1
74	WEDGE PROTECTOR	1



BBTA.COM.AU

Copyright © Bigger Boyz Toyz Australia

Unit 2/3 Delta Place Albion Park Rail NSW 2527 • 02 4257 4787

