

# OWNER'S MANUAL

## Assembly & Operating Instructions

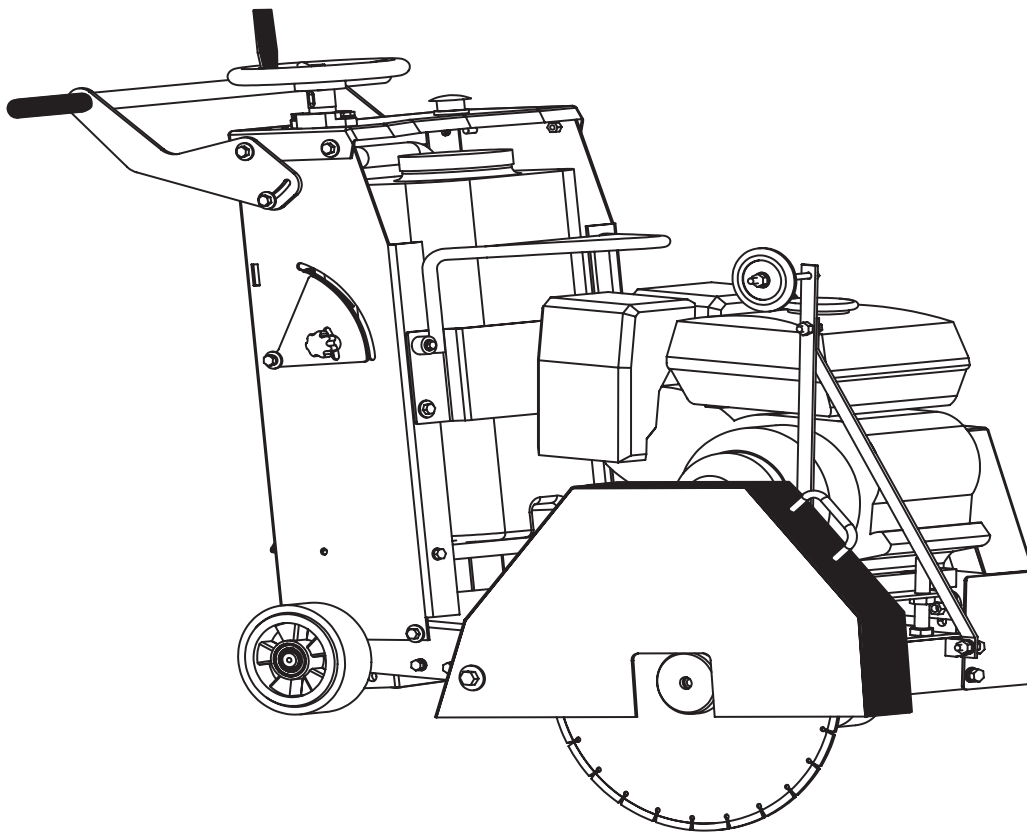

### CONCRETE CUTTER

CUT20B.V24



Thank you for choosing our Equipment. It was carefully engineered to provide excellent performance when properly operated and maintained.

Please read this entire manual before operating the Equipment. It instructs you on how to set up, operate, and maintain your Equipment safely and easily. Ensure that you and any other persons operating the Equipment carefully follow the recommended safety practices at all times, as failure to do so could result in personal injury or property damage.

All information in this manual is relevant to the most recent product information available at the time of printing. Review this manual frequently to familiarize yourself with the machine, its features, and operation. Please note that this Owner's Manual may cover a range of product specifications for various models. Characteristics and features discussed and/or illustrated in this manual may not be applicable to all models. We reserve the right to change product specifications, designs, and equipment without notice and without incurring obligation.

All the power testing information used to establish the power rating of the engine equipped on this Equipment can be found in the engine manufacturer's manual or website. If you encounter any problems or have questions about the machine, please contact our Customer Support Department.

Throughout this manual, all references to the right and left side of the Equipment are observed from the operating position. The engine manufacturer is responsible for all engine-related issues concerning performance, power-rating, specifications, warranty, and service. Refer to the engine manufacturer's Owner's Manual, packed separately with your Equipment, for more information.

## **Customer Support**

Before initiating a product return, kindly reach out to our dedicated Customer Support Department at Bigger Boyz Toyz. We are here to assist you.

Phone: 02 4257 4787

Email: [bbt@bbta.com.au](mailto:bbt@bbta.com.au)

Warehouse: Unit 2/3 Delta Place, Albion Park Rail NSW 2527

If you have difficulty assembling the product or have any questions about the controls, operations, or maintenance of the equipment, please don't hesitate to get in touch with our Customer Support Department.

# CONTENTS

<b>SAFETY &amp; ALERT SYMBOLS .....</b>	<b>4</b>
FOR YOUR SAFETY AND THE SAFETY OF <u>OTHERS!</u> .....	4
<b>ADDITIONAL INFORMATION AND POTENTIAL CHANGES .....</b>	<b>4</b>
<b>HAZARDS SYMBOLS .....</b>	<b>5</b>
<b>GENERAL SAFETY .....</b>	<b>6</b>
TRANSPORTING .....	7
MAINTENANCE.....	7
EMERGENCIES.....	7
DIAMOND BLADE SAFETY .....	7
CUTTER TRANSPORTATION SAFETY:.....	7
MAINTENANCE SAFETY:.....	8
ADDITIONAL HAZARD .....	8
<b>GENERAL INFORMATION.....</b>	<b>8</b>
APPLICATION.....	8
<b>OPERATION.....</b>	<b>9</b>
CHECK BEFORE .....	9
INSTALLING BLADE .....	9
TYPE OF CUTTING .....	9
BEFORE STARTING.....	9
START THE ENGINE .....	9
START CUTTING .....	10
CUTTING.....	10
BELTS & PULLEYS.....	10
DRY CUTTING.....	11
<b>TROUBLE SHOOTING.....</b>	<b>12</b>
<b>LUBRICATION AND SERVICE .....</b>	<b>15</b>
<b>REPLACEMENT PARTS LIST.....</b>	<b>16</b>

# SAFETY & ALERT SYMBOLS

## FOR YOUR SAFETY AND THE SAFETY OF OTHERS!



Safety precautions should be followed all the time when operating this equipment. Failure to read and understand the Safety Messages and Operating Instructions could result in injury to yourself and others



This Operating Instructions has been developed to provide complete instructions for the safe and efficient operation of this equipment. Refer to the engine manufactures instructions for data relative to its safe operation.



**WARNING:** Read and thoroughly understand all instructions in this equipment and on the safety decals before assembling or operating this equipment. Failure to do so may cause serious injury or death. Do not allow anyone to operate this equipment who has not read this manual. As with all power equipment, this equipment can be dangerous if assembled or used improperly. Do not operate this equipment if you

have any questions concerning its safe operation. Contact our Customer Support Department for assistance in addressing any queries or concerns.

This SAFETY ALERT SYMBOL identifies important safety messages in this manual. Failure to follow this important safety information may result in serious injury or death.



**DANGER** indicates a hazardous situation which, if not avoided, will result in serious injury or death.



**WARNING** indicates a hazardous situation which, if not avoided, could result in serious injury or death.

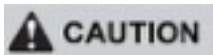

**CAUTION** indicates a hazardous situation which, if not avoided, could result in minor or moderate injury.

## ADDITIONAL INFORMATION AND POTENTIAL CHANGES

We reserve the right to discontinue, change, and improve our products at any time without notice or obligation to the purchaser. The descriptions and sections contained in this manual were in effect at the time of printing. Equipment described within this manual may be optional. Some illustrations may not be applicable to your machine.















Your Responsibility—Restrict the use of this power machine to persons who have read, understood, and will follow the warnings and instructions in this manual and on the machine

**SAVE THESE INSTRUCTIONS!**

# HAZARDS SYMBOLS

Potential hazards associated with the operation of this equipment will be referenced with Hazard Symbols which appear throughout this manual.

	<b>READ THE OWNER'S MANUAL(S)</b> : Read, understand and follow all instructions in the manual(s) before attempting to assemble and operate.
	<b>FACE PROTECTION</b> : Always wear safety goggles or safety glasses with side shields or a face shield when operating this product as well as ear protection.
	<b>WEAR GLOVES</b> : Always wear non-slip, heavy-duty protective gloves when operating this product.
	<b>WEAR SAFETY FOOTWEAR</b> : Always wear non-slip steel-toed safety footwear when operating this product.
	<b>BEWARE OF ROTATING BLADES</b> : This equipment has a rotating cutting blade capable of amputating hands and feet and throwing objects. Keep hands and feet out of openings while machine is running. Failure to observe these safety instructions could result in serious injury or death.
	<b>BEWARE OF FLYING OBJECTS</b> : Beware of thrown objects, which can ricochet causing serious injury to the eyes. Always wear eye & ear protection when operating.
	Never wear loose clothes or long jewellery and keep your long hair secured when operating machine. Never operate this machine in bare feet or sandals. Never use machine on a slope or hard smooth floor.
	<b>CARBON MONOXIDE AND GAS</b> : Exhaust contains poisonous carbon monoxide, a colourless and odourless gas. Breathing exhaust fumes can cause loss of consciousness and may lead to death.
	<b>RESPIRATORY HAZARDS</b> : ALWAYS wear approved respiratory protection when required.
	<b>PETROL OIL</b> : Petrol is extremely flammable and the vapours are explosive. Serious personal injury can occur when petrol is spilled on you or your clothing, which can ignite. In the event of a petrol spill, wash your skin and change clothes immediately.
	<b>BURN HAZARDS</b> : Engine components can produce intense heat. To avoid burns, DO NOT touch these areas while the engine is running or right after operations. Never operate the engine with removed heat shields or guards.
	DO NOT use in the rain.
	<b>ACCIDENTAL STARTING HAZARDS</b> : Always place the <b>ON/OFF</b> switch in the <b>OFF</b> position when the equipment is not in use.

# GENERAL SAFETY

- » DO NOT operate or service this equipment before reading this entire manual.
- » This equipment should not be operated by persons under 18 years of age.
- » NEVER operate this equipment without proper protective clothing, shatterproof glasses, steel-toed boots, and other protective devices required for the job.
- » NEVER operate this equipment when not feeling well due to fatigue, illness, or taking medicine.
- » NEVER operate this equipment under the influence of drugs or alcohol.
- » ALWAYS wear proper respiratory (mask), hearing, and eye protection equipment when operating the equipment.
- » Whenever necessary, replace the nameplate, operation, and safety decals when they become difficult to read.
- » The manufacturer does not assume responsibility for any accidents due to equipment modifications.
- » NEVER use accessories or attachments that are not recommended for this equipment. Damage to the equipment and/or injury to the user may result.
- » NEVER touch the hot exhaust manifold, muffler, or cylinder. Allow these parts to cool before servicing the engine or equipment.
- » High Temperatures – Allow the engine to cool before adding fuel or performing service and maintenance functions. Contact with hot components can cause serious burns.
- » The engine section of this equipment requires an adequate free flow of cooling air. NEVER operate the equipment in any enclosed or narrow area where the free flow of air is restricted; it will cause serious damage to the equipment or engine and may cause injury to people.
- » ALWAYS refuel in a well-ventilated area, away from sparks and open flames.
- » ALWAYS use extreme caution when working with flammable liquids. When refuelling, stop the engine and allow it to cool.
- » NEVER operate the equipment in an explosive atmosphere or near combustible materials. An explosion or fire could result, causing severe bodily harm or even death.
- » DO NOT smoke around or near the machine. Fire or explosion could result from fuel vapours, or if fuel is spilled on a hot engine.
- » Topping-off to the filter port is dangerous, as it tends to spill fuel.
- » Stop the engine when leaving the equipment unattended.
- » Maintain this equipment in a safe operating condition at all times.
- » ALWAYS stop the engine before servicing, adding fuel and oil.
- » NEVER run the engine without an air filter. Severe engine damage may occur.
- » ALWAYS service the air cleaner frequently to prevent carburetor malfunctions.
- » ALWAYS check the machine for loosened threads or bolts before starting.
- » ALWAYS ensure the operator is familiar with proper safety precautions and operational techniques before using the equipment.
- » ALWAYS store equipment properly when it is not being used. Equipment should be stored in a clean, dry location out of the reach of children.
- » DO NOT operate this equipment unless all guards and safety devices are attached and in place.
- » CAUTION must be exercised while servicing this equipment.
- » Keep all inexperienced and unauthorized people away from the equipment at all times.

- » Unauthorized equipment modifications will void all warranties.
- » NEVER pour or spray water over the engine.
- » Test the engine ON/OFF switch before operating. The purpose of this switch is to shut down the engine of the equipment.
- » Refer to the Engine User's Manual for engine technical questions or information recommended for the equipment.

## TRANSPORTING

- » ALWAYS shut down the engine before transporting.
- » Tighten the fuel tank cap securely and close the fuel cock to prevent fuel from spilling.
- » Drain fuel when transporting the equipment over long distances or bad roads.
- » When placing the equipment inside a truck bed for transport, always tie down the equipment.

## MAINTENANCE

- » NEVER lubricate components or attempt service on a running equipment.
- » ALWAYS allow the equipment a proper amount of time to cool before servicing.
- » Keep the equipment in proper running condition.
- » Fix damage to the equipment immediately and always replace broken parts.
- » Dispose of hazardous waste properly. Examples of potentially hazardous waste are used motor oil, fuel, and fuel filters.
- » DO NOT use wooden or plastic containers to dispose of hazardous waste.

## EMERGENCIES

- » ALWAYS know the location of the nearest fire extinguisher and first aid kit.
- » In emergencies, always know the location of the nearest phone or keep a phone on the job site. Also, know the phone numbers of the nearest ambulance, doctor, and

fire department. This information will be invaluable in the case of an emergency.

## DIAMOND BLADE SAFETY

- » Use appropriate steel-centred diamond blades manufactured for use on concrete cutters.
- » Always inspect diamond blades before each use. The blade should show no cracks, dings, or flaws in the steel-centred core and/or rim. The centre (arbour) hole must be undamaged and true.
- » Examine blade flanges for damage, excessive wear, and cleanliness before mounting the blade.
- » The blade should fit snugly on the shaft and against the inside/outside blade flanges.
- » Ensure that the blade is marked with an operating speed greater than the blade shaft speed of the cutter.
- » Only cut the material specified by the diamond blade. Read the specifications of the diamond blade to ensure the proper tool has been matched to the material being cut.
- » Always keep blade guards in place. Exposure of the diamond blade must not exceed 180 degrees.
- » Ensure that the diamond blade does not contact with the ground or surface during transportation.
- » Do not drop the diamond blade on the ground or surface.
- » The engine governor is designed to permit maximum engine speed in a no-load condition. Speeds that exceed this limit may cause the diamond blade to exceed the maximum safe allowable speed.
- » Ensure that the blade is mounted in the proper operating direction.

## CUTTER TRANSPORTATION SAFETY:

- » Use the lifting bail and appropriate lifting equipment to ensure the safe movement of the cutter.



- » Do not use the handle bars and/or front pointer as lifting points.
- » Never tow the saw behind a vehicle.
- » Ensure that both pointer bars are positioned appropriately to minimize their exposure during transportation.
- » Safeguard against extreme cutter attitudes relative to lever. Engine tipped to extreme angles may cause oil to gravitate into the cylinder head, making the engine difficult to start.
- » Never transport the cutter with the blade mounted.

## **MAINTENANCE SAFETY:**

- » Never lubricate components or attempt service on a running machine.
- » Always allow the machine a proper amount of time to cool before servicing.
- » Immediately fix any damage to the machine and always replace broken parts.
- » Dispose of hazardous waste properly. Examples of potentially hazardous waste include used motor oil, fuel, and fuel filters.
- » Do not use food or plastic containers to dispose of hazardous waste.

## **ADDITIONAL HAZARD**

- » Do not operate this equipment unless all guards and safety devices are securely attached and in place. Exercise caution when servicing, as rotating and moving parts can cause injury if contacted. Ensure that inexperienced and unauthorized individuals are kept away from the equipment at all times. Unauthorized modifications to the equipment will result in voiding all warranties.

# **GENERAL INFORMATION**

## **APPLICATION**

These machines are primarily designed for “flat” sawing, where the pavement is cut close to a horizontal plane, representing the most common type of diamond blade cutting.

Concrete cutters in the industry come in various types, sizes, and styles, ranging from manual to self-propelled with horsepower varying from 7 to 72hp. They are capable of cutting both concrete (green or cured, with or without rebar) and asphalt. Our MF12 model is specifically tailored for precision cutting tasks, including floors, pavements, walkways, ramps, and other flat sawing applications, ensuring versatility for a wide range of job requirements.

Upon receiving your machine, carefully inspect it for any freight damage. Promptly report any damage to the carrier and register a claim as necessary.



# OPERATION

## CHECK BEFORE

Upon taking delivery of your new equipment, ensure to read the handbook completely, including the supplied engine manual, and check the general condition for any damage incurred during delivery. Additionally, verify the engine oil level and fuel levels before putting the equipment into service.

## INSTALLING BLADE

- » Ensure that the spark plug is disconnected or the saw is unplugged.
- » Remove the blade shaft nut and take off the outside blade shaft flange.
- » Clean off any foreign particles on the clamping surfaces of the flanges and on the mounting surface of the blade.
- » Place the blade on the blade shaft, aligning the offset drive pin in the blade with the drive pin in the mounting collar (if the pin system is available on the machine). If your blade has a directional rotational arrow, position the arrow for a down cut (diamond tail trailing for a down cut).
- » Replace the outside blade shaft flange on the blade shaft. The drive pin on the inside collar must project through the drive in the blade and into the outside collar (if the pin system is available on the machine).
- » Tighten the blade shaft nut securely against the star washer and outside flange, using the wrench supplied.
- » Reconnect the spark plug or (with the switch "off") plug in the electric supply cord.

## TYPE OF CUTTING

The cutting speed depends entirely on using the correct blade for the material to be cut. Diamond blades with various specifications, suitable for cutting concrete or asphalt, are available for both wet and dry cutting methods.

## BEFORE STARTING

- » Use the correct blade for cutting conditions.
- » Ensure arbours and flanges are clean and undamaged.
- » Mount the blade and tighten it securely using a wrench.
- » When wet cutting, check water jets for adequate flow.
- » Align the pointer with the cutter blade.

### CAUTION

Set up the unit in an open area. Avoid close proximity to structures or other equipment. Failure to do so may cause inadvertent injury to the operator or other persons in the area.

## START THE ENGINE

### Cold Start:

Open the fuel valve under the gas tank fully. Position the engine stop switch, located on the engine, to the "run" position. Open the throttle approximately halfway and engage the choke. Pull the starter rope sharply. Once the engine starts, release the choke and adjust the throttle as needed to maintain a steady idle. Allow the engine to warm up for a few minutes before applying any load. If the engine fails to start after three pulls, slightly open the choke to prevent flooding. Remember to always operate the engine at full throttle when under load.

### Hot Start:

Fully open the valve under the gas tank if it has been shut off. Open the throttle approximately halfway. Do not engage the choke. Pull the starter rope sharply until the engine starts. Once the engine is running, adjust the throttle as needed. Remember to always operate the engine at full throttle when under load.

NOTE: These starting instructions are general guidelines only. Since many engine options are available, consult the Engine Manual included with this unit for specific instructions.

## CAUTION

Petrol Engines: To improve the engine service life, allow the engine to idle without load for 2-5 minutes before shutting it down. When the idling period is up, use the stop switch located on the engine and turn it to "stop". Close the fuel valve under the fuel tank. Engine flooding can occur if the valve is left open during transport.

## START CUTTING

- » Start the engine and allow it to warm up. All cutting should be done at full throttle.
- » Align the blade and cutter with the cut. If wet cutting, open the water valve and turn on the water safety switch.
- » Lower the blade into the cut slowly.
- » Cut at the maximum speed the blade allows. If the blade starts to climb out of the cut, reduce the forward speed or depth of cut.
- » Apply only enough side pressure on the cutter handles to follow the cutting line.

## CUTTING

Lower the blade into the concrete to the required depth by turning the tilt crank counter clockwise. Advance the saw slowly forward, easing forward pressure if the saw begins to stall.

Note: For deeper cuts (4 inches/102mm or more), make several cuts in incremental steps of 1-1/2 inches (38mm) to 2 inches (51mm) until the desired depth is reached. Push the saw steadily forward, using the front pointer as a guide. Apply enough forward pressure so that the engine/motor starts to labour but does not slow down. If the saw starts to stall, reduce forward movement until full RPM is restored to the blade. If the saw stalls, raise the blade out of the cut before restarting. Avoid excessive side pressure or twisting of the blade in the cut.

## BELTS & PULLEYS

NEVER MAKE ADJUSTMENTS TO V-BELTS AND PULLEYS WHILE THE ENGINE IS RUNNING.

1. The best tension for a V-belt drive is the lowest tension at which the belts will not slip under full load.
2. Tighten the belts until they are snug in the grooves. Run the drive for about five minutes to "seat" the belts. This will impose the peak load. If the belts slip, tighten them until they no longer slip at peak load. Most new belts will need additional tensioning after seating.
3. Remember, excessive tension shortens belt and bearing life.
4. Check the belt tension frequently during the first day of operation. Periodically thereafter, check the belt tension and make any necessary adjustments.
5. The two most common causes of sheave misalignment are: a) The engine drive shaft and the blade shaft are not parallel. b) The pulleys are not properly located on the shafts.
6. To check alignment, use a steel straight edge (see Figure 1).

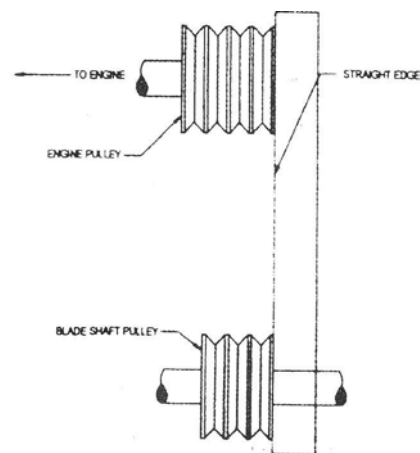

Figure 1

7. Align the straight edge along the outside face of both pulleys shown in the drawing. All pulleys have 2 set screws in the bottom of their grooves. These set screws require thread locking.

8. Misalignment will be indicated by a gap between the pulley face and the straight edge. Ensure there is clearance between the arbour pulley and the saw base on both sides.

## **DRY CUTTING**

- » Never operate any saw without safety guards in place.
- » Do not exceed the maximum operating speed established for the blade diameter. Allow the blade to cut at its own speed; do not force it into the material.
- » Avoid making long continuous cuts. Never dry cut for more than 30 seconds at a time; allow the blade to cool.
- » Do not cut or grind the side of the blade or attempt to cut a curve or radius with it. Additionally, do not use blades recommended for wet cutting for dry cutting purposes.
- » Do not operate the saw with a blade diameter larger than the machine's capacity.

# TROUBLE SHOOTING

PROBLEM	CAUSE	REMEDY
Uneven Segment Wear	<ul style="list-style-type: none"> <li>» Insufficient water (usually on one side of the blade) in wet cutting.</li> <li>» Equipment defects can also cause the segments to wear unevenly.</li> <li>» Misalignment of the saw head.</li> </ul>	<ul style="list-style-type: none"> <li>» Flush the water system.</li> <li>» Check the flow to both sides of the blade.</li> <li>» Replace worn head bearings, arbour shaft, or correct misalignment of the spindle.</li> <li>» Check the alignment for squareness, both vertically and horizontally, of the saw blade.</li> </ul>
Segment Cracks	<ul style="list-style-type: none"> <li>» Blade is too hard for the material being cut.</li> </ul>	<ul style="list-style-type: none"> <li>» Use a blade with a softer bond/matrix.</li> </ul>
Segment Loss	<ul style="list-style-type: none"> <li>» Blade overheats because of coolant (water or air).</li> <li>» Core is worn from undercutting.</li> <li>» Defective collars/flanges set blade out of alignment.</li> <li>» Blade is too hard for the material being cut.</li> <li>» Blade is cutting out of round, causing a pounding motion.</li> <li>» Improper blade tension.</li> </ul>	<ul style="list-style-type: none"> <li>» (Wet Cutting) Check water lines</li> <li>» Make sure flow is adequate on both sides of blade and there are no blockages</li> <li>» Use sufficient water to flush out the cut</li> <li>» (Dry cutting) Run blade free of cut periodically to air cool</li> <li>» Clean collars / flanges or replace if they are under recommended diameter</li> <li>» Use proper blade specification for material being cut</li> <li>» Replace worn bearings; realign blade shaft or replace worn blade mounting arbor</li> <li>» When ordering blades match shaft speed of saw</li> <li>» Check spindle speed to ensure blade is running at correct RPM</li> <li>» Avoid twisting or turning blade in the cut</li> </ul>

PROBLEM	CAUSE	REMEDY
Cracks in Core	<ul style="list-style-type: none"> <li>» Blade flutters in the cut as a result of losing blade tension.</li> <li>» Blade specification is too hard for the material being cut.</li> </ul>	<ul style="list-style-type: none"> <li>» Tighten the blade shaft nut to ensure proper tension.</li> <li>» Ensure the blade is running at the proper speed and that the drive pin is functioning properly.</li> <li>» Use a softer bond/matrix to eliminate stress on the blade.</li> </ul>
	<ul style="list-style-type: none"> <li>» Core overheating.</li> <li>» Core overheating as a result of the blade spinning on the arbour.</li> <li>» Core overheating from rubbing the material being cut.</li> <li>» Unequal pressure at blade clamping collars/flanges.</li> <li>» Blade is too hard for the material being cut.</li> </ul>	<ul style="list-style-type: none"> <li>» Ensure blade RPM is correct.</li> <li>» Check water flow, distribution, and lines.</li> <li>» Tighten the blade shaft nut and ensure the drive pin is functioning properly.</li> <li>» Properly align the saw for a square cut.</li> <li>» Ensure collars/flanges are identical in diameter and the recommended size.</li> <li>» Use a softer bond/matrix to reduce stress on the blade.</li> </ul>
Blade Wobbles	<ul style="list-style-type: none"> <li>» Blade is on a damaged or worn saw.</li> <li>» Worn collar.</li> <li>» Blade runs at an incorrect speed.</li> <li>» Collar/flange diameters are not identical.</li> <li>» Blade is bent as a result of dropping or twisting.</li> </ul>	<ul style="list-style-type: none"> <li>» Check collars/flanges to make sure they are clean, flat, and of correct diameter.</li> <li>» Set engine at proper RPM.</li> <li>» Use proper size blade collars/flanges.</li> <li>» Do not use bent blade. Contact blade manufacturer.</li> </ul>
Blade will not cut	<ul style="list-style-type: none"> <li>» Blade is too hard for the material being cut.</li> <li>» Blade has become dull.</li> <li>» Blade does not cut the material it was specified for.</li> </ul>	<ul style="list-style-type: none"> <li>» Select the proper blade for the material being cut.</li> <li>» Sharpen by cutting on softer abrasive material to expose diamonds. If continually sharpening, the blade is too hard for the material being cut.</li> <li>» Break-in on the material to be cut. If it does not dress itself, sharpen as you would a dull blade.</li> </ul>

PROBLEM	CAUSE	REMEDY
Undercutting the Steel Center	<ul style="list-style-type: none"> <li>» Abrasive wearing of the core faster than the segments.</li> </ul>	<ul style="list-style-type: none"> <li>» Use water to flush out fines generated during cutting.</li> <li>» Use wear-resistant cores.</li> </ul>
Arbour hole out-of-round	<ul style="list-style-type: none"> <li>» Collars/flanges are not properly tightened, permitting the blade to rotate or vibrate on the shaft.</li> <li>» Collars/flanges are worn or dirty, and the blade is not properly mounted.</li> <li>» Shaft bearings are worn.</li> <li>» Surges occur because the engine is not properly tuned.</li> <li>» Blade arbour hole is damaged from incorrectly mounting the blade.</li> <li>» Bond/matrix is too hard for the material.</li> <li>» Blade is slipping, wearing one half of the blade more than the other.</li> <li>» Check for bad bearings, bent shaft, or worn mounting arbour.</li> </ul>	<ul style="list-style-type: none"> <li>» Ensure that the blade is mounted on the proper shaft diameter. Tighten the shaft nut with a wrench to ensure that the blade is secure.</li> <li>» Clean collars/flanges and make sure they are not worn. Tighten the arbour nut.</li> <li>» Ensure that the pin hole slides over the drive pin.</li> <li>» Install new blade shaft bearings or blade shaft, as required.</li> <li>» Tune the engine according to the manufacturer's manual.</li> <li>» If the core is worn or the arbour hole is damaged, DO NOT USE. Contact the blade manufacturer.</li> <li>» Replace worn shaft or mounting arbour bushing.</li> <li>» Ensure that the drive pin is functioning.</li> <li>» Tighten the spindle nut.</li> </ul>

# LUBRICATION AND SERVICE

- » Check oil levels, wiring, and hoses (air, fuel, water) daily, and lubricate the machine accordingly. Repair or replace all worn or damaged components immediately.
- » Ensure drive belt tension is appropriate, avoiding over-tensioning. Confirm the machine has a full set of matched belts.
- » Inspect the blade shaft to ensure the arbour and threads are not worn, damaged, or bent. Blade shaft bearings should be tight with no free play side-to-side or up and down. Grease blade shaft bearings daily.
- » Verify that blade collars are clean, free of nicks and burrs, and have no diameter wear or irregularities. The drive pin should not be excessively worn or bent and must be free of gouges.
- » Ensure all guards are in place and secure, and all fasteners are tight.
- » Keep the air filter/oil filter (hydraulic or engine) clean.
- » Flush clean water through the pump and spray assembly every night to prolong pump and blade life.
- » Clean the machine before starting lubrication maintenance and ensure it is on solid, level ground.
- » During lubrication maintenance, maintain strict cleanliness at all times. Use the correct tool for the job and keep tools clean. Drain engine oil when warm, not hot, to avoid accidents.
- » Clean up any spilled oil immediately and use only clean containers for oil and fresh oils and grease of the correct grade. Dispose of contaminated water/fluids/oil/filters safely.



# REPLACEMENT PARTS LIST

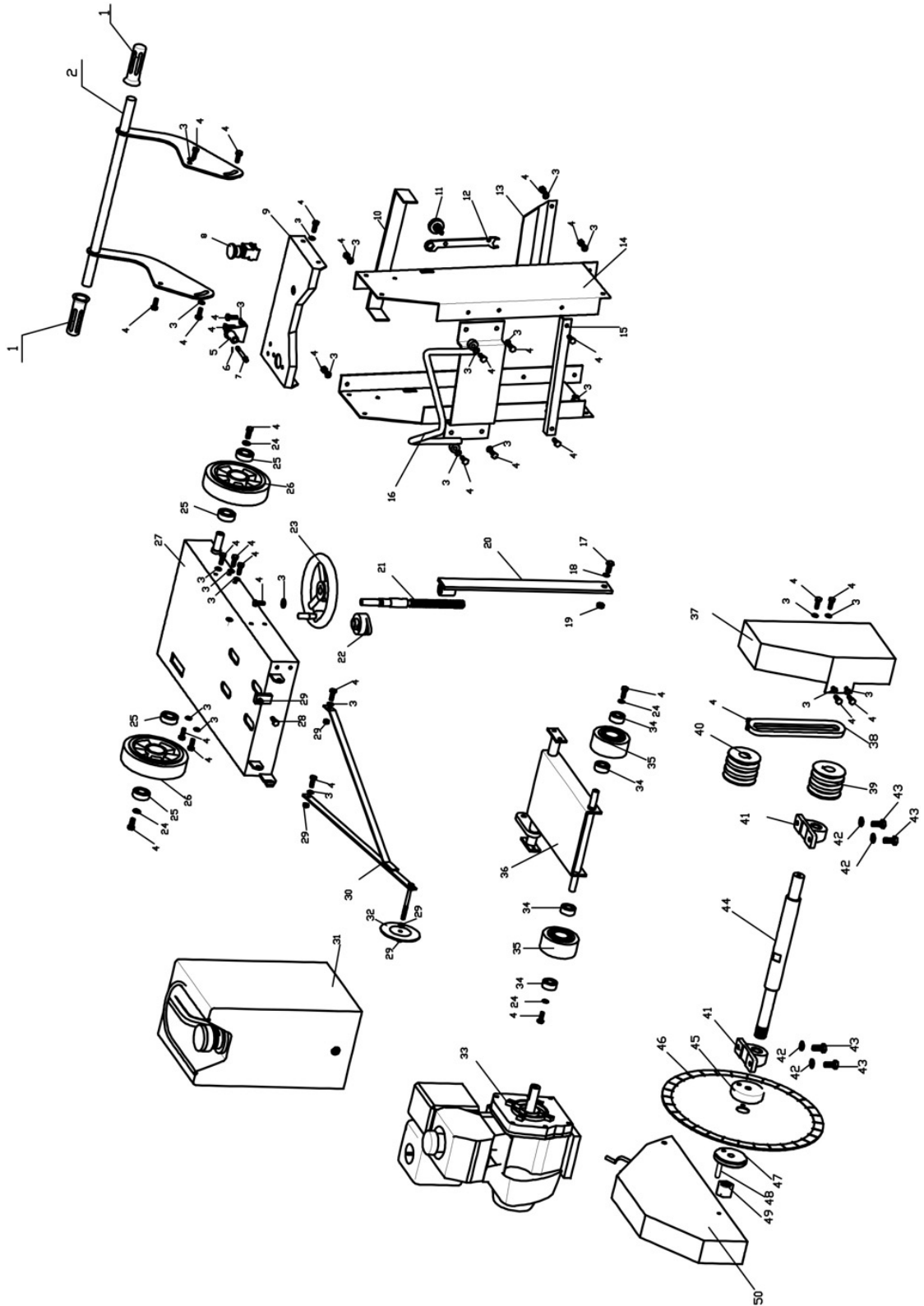

PART NO.	DESCRIPTION	QYT
CNQ20B001	Handle grip	2
CNQ20B002	Handle (set)	1
CNQ20B003	Flat washer M8	32
CNQ20B004	Screw M8*20	36
CNQ20B005	Lock system	1
CNQ20B006	Lock pin	1
CNQ20B007	Lock pin	1
CNQ20B008	Switch,emergency stop	1
CNQ20B009	Cover of water tank	1
CNQ20B010	Bandage	1
CNQ20B011	Knob	1
CNQ20B012	Wrench	1
CNQ20B013	Rear support plate for water tank	1
CNQ20B014	Side plate for water tank (set)	1
CNQ20B015	Front support plate for water tank	1
CNQ20B016	Lifting hook	1
CNQ20B017	Screw M10*30	1
CNQ20B018	Flat washerφ10	1
CNQ20B019	Screw M10	1
CNQ20B020	Jackpost assy.	1
CNQ20B021	Jackscrew	1
CNQ20B022	Bearing LF204	2
CNQ20B023	Wheel	1
CNQ20B024	Bigger flat washer φ8	2

PART NO.	DESCRIPTION	QYT
CNQ20B025	Bearing for real shaft	4
CNQ20B026	Rear wheel	2
CNQ20B027	Base plate	1
CNQ20B028	Screw M8*90	1
CNQ20B029	Nut M8	6
CNQ20B030	Pointer arm	1
CNQ20B031	Water tank	1
CNQ20B032	Pointer wheel	1
CNQ20B033	Engine	1
CNQ20B034	Bearing for front wheel	4
CNQ20B035	Front wheel	2
CNQ20B036	Wheel rack module	1
CNQ20B037	Belt cover	1
CNQ20B038	Belt	3
CNQ20B039	Pulley, driven	1
CNQ20B040	Pulley,engine	1
CNQ20B041	Bearing seat UCP205	2
CNQ20B042	Bigger flat washer φ12	4
CNQ20B043	Screw M12*40	4
CNQ20B044	Main shaft	1
CNQ20B045	Blade flange (inner)	1
CNQ20B046	Blade	1
CNQ20B047	Blade flange (outer)	1
CNQ20B048	Pin,flange	1
CNQ20B049	Screw for main shaft	1
CNQ20B050	Blade cover	1



**BIGGER BOYZ TOYZ**  
COMMERCIAL

**BBTA.COM.AU**

Copyright © Bigger Boyz Toyz Australia

Unit 2/3 Delta Place Albion Park Rail NSW 2527 • 02 4257 4787

